

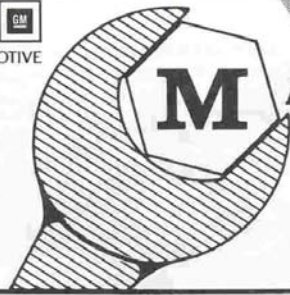

M.I. 1501
*Rev. B



MAINTENANCE INSTRUCTION

LOCOMOTIVE SWING HANGER AND SWITCHER TRUCK ASSEMBLIES EQUIPPED WITH CLASP BRAKES

INTRODUCTION

This bulletin covers two basic types of trucks equipped with clasp type brakes; the swing hanger truck, Fig. 1, and the rigid (switcher) truck, Fig. 2. Two different models of swing hanger trucks are included. One, a four wheel two motor truck, is used on GP, "F", and MP type locomotives and the other, a six wheel two motor truck, is used on "E" type locomotives. The four wheel two motor rigid truck with the bolster and frame cast as a unit, is used only on switchers.

DESCRIPTION

The trucks support the weight of the locomotive and provide a means for transmission of power to the rails. They are designed to withstand the stress resulting from road shock due to normal variations in the roadbed and other conditions encountered during operation. An important function of the truck assembly is to absorb and nullify these stresses so they will not be transmitted to the locomotive underframe and the equipment mounted on the underframe.

The locomotive tractive horsepower is supplied to the traction motors. The motors are geared to the driving axles which in turn apply this force to the rail through the wheels. The tractive force is transmitted through the axle journal boxes to the truck frame and through truck frame pressure areas to mating pressure areas on the truck bolster. The bolster then transmits the force through its center

bearing to the carbody center plate to move the locomotive and supply the locomotive draw bar horsepower.

Air brake cylinders and brake rigging mounted on the trucks are used to apply retarding force to the wheels to slow and stop the locomotive.

SWING HANGER TRUCKS

The main frame of the swing hanger truck, Fig. 1, is supported on sets or nests of coil springs, two of which are above each journal box on the four wheel swing hanger truck and two of which are seated in each spring dome on the six wheel swing hanger truck. On the four wheel truck the journal box transmits the load directly from the springs to the axle but on the six wheel truck, equalizer bars spanning the center and end journal boxes, distribute the load from four sets of springs to the six journal boxes.

Each journal box is held between the pedestal jaws, which are an integral part of the frame. Each pair of pedestals is joined at the bottom by a pedestal tie bar, which is an important part of the weight carrying system. Renewable pedestal liners and journal box wear plates provide control of clearances between the pedestals and journal boxes.

Bosses on both sides of the frames are provided to support the swing hangers, which carry the spring plank. Two spring planks are used on the six wheel truck. Full elliptic springs at each end of the spring plank support the bolster, which is confined between the insides of the frame transoms.

*This bulletin is revised and supersedes previous issues of this number.

DE-L

August 1979

M.I. 1501

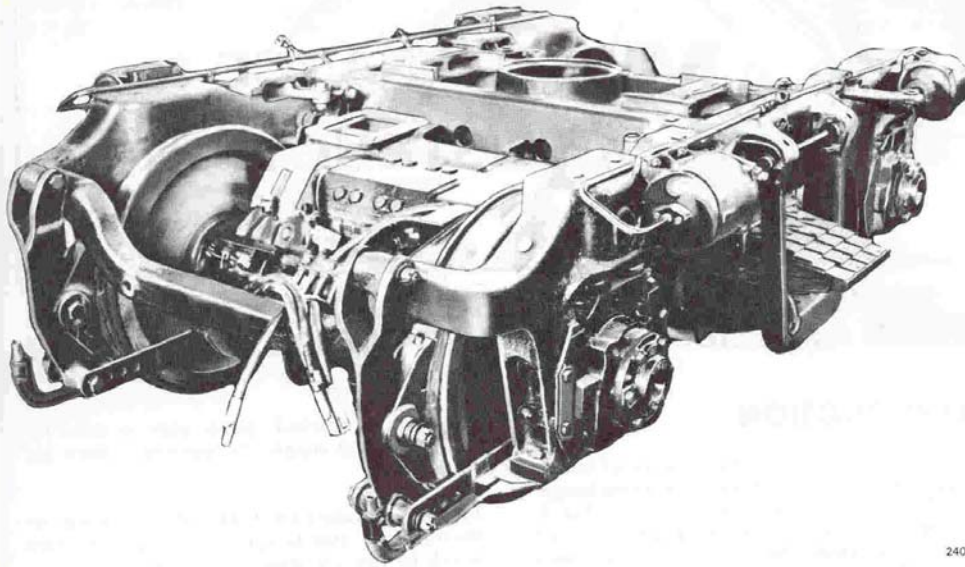

24098

Four Wheel

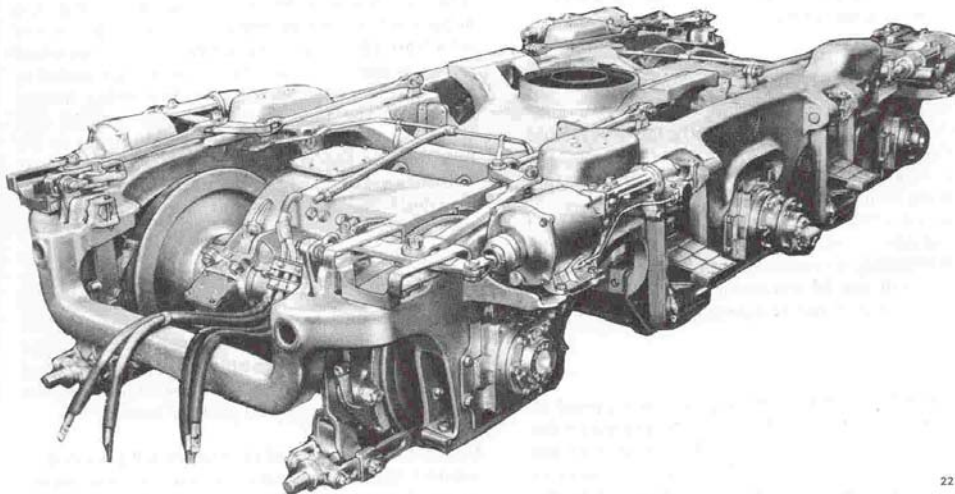

22148

Six Wheel

Fig.1 - Four Wheel And Six Wheel Swing Hanger
Truck Assemblies

Driving or braking forces are transferred from the frame transoms to the bolster. Wear plates on the inside surface of each transom contact mating wear surfaces on the bolster. The bolster center bearing, in turn, transfers these motive forces to the carbody center bearing. Side bearings on the truck bolster and matching devices on the carbody limit the lean of the locomotive. Clips bolted to the carbody side bearings hook under the bolster side bearings to allow rotary movement between the carbody and truck bolsters but prevent separation of the bolster from the carbody underframe. They also provide anti-slewing protection in case of derailments.

Traction motors are supported on their respective drive axles and at the traction motor nose suspension assembly mounted on the transom. The six wheel truck bolster center casting is designed so that traction motor cooling air can be forced down through it into both traction motors.

Brake cylinder pistons are connected to brake levers to actuate the brake rigging. On the four wheel truck each cylinder actuates the brakes on one wheel, but on the six wheel truck each brake cylinder actuates the linkage to three shoes—two on the end wheel and one on the idler wheel.

SWITCHER TRUCKS

The four wheel switcher truck, Fig. 2, is referred to as a rigid truck since the bolster and frame are a one piece casting, with no lateral motion being provided between them.

The side frames of the truck are joined at the ends by offset end transoms and at the middle by the integral bolster. The center bearing receives the mating carbody center plate. The center bearing has a circular opening which serves as an air duct for the cooling air to the traction motors. A rectangular opening is provided at each side of the hollow bolster to duct the cooling air through flexible rubber ducts which are connected to the bolster and the traction motor.

The weight supported by the frame is transferred to the journal boxes through a pair of equalizers spanning the boxes, plus a spring system on each side of the frame. A pair of double coil springs and a semi-elliptic spring is held between each pair of equalizers and the side frame. The coil spring upper ends are contained in spring pockets in the frame and supported on spring seats mounted on the equalizers. The ends of the elliptic springs are supported on spring hangers.

Two traction motors, facing opposite directions, are supported on their respective drive axles and at the traction motor nose suspension assembly mounted on the transoms.

One brake cylinder containing two pistons is mounted on each side of the frame. Each cylinder actuates the clasp type friction brakes for both wheels on one side.

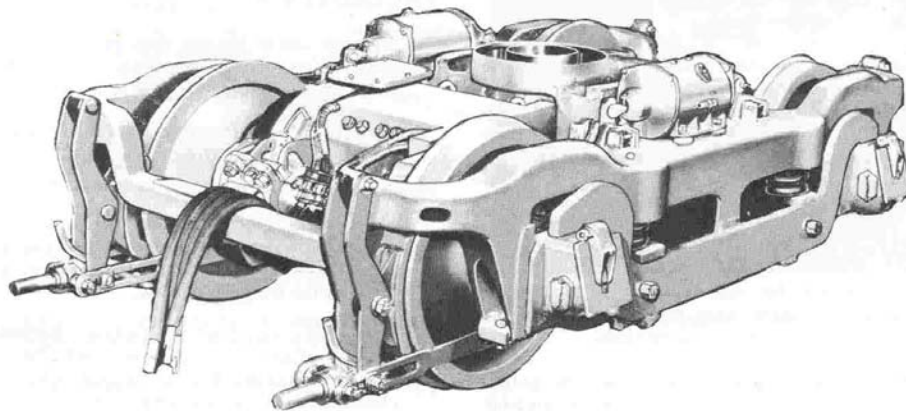

Fig.2 - Switcher Truck Assembly

22149

M.I.1501

MAINTENANCE

LUBRICATION

Journal box oil level should be inspected periodically and oil added if necessary. Screw type slack adjuster threads should be coated with graphite grease.

The center bearing should have approximately 3.3 litres (7 pints) of oil added at time unit is trucked. On locomotives equipped with center bearing oil fill pipes add 1.7 litres (3-1/2 pints) to center bearing before unit is trucked. This will be sufficient to cover center bearing wear plate. After unit has been trucked, add an additional 1.7 litres (3-1/2 pints) through center bearing oil fill pipe.

Special care should be taken to keep journal box and pedestal jaw wear surfaces free of oil or grease.

TRUCK CLEANING UNDER LOCOMOTIVE

Trucks should be periodically cleaned while under locomotive to eliminate any accumulation of oil and road dirt. An oily accumulation presents a fire hazard and tends to increase wear of moving parts on the truck, as well as detract from general appearance of trucks.

CAUTION

When cleaning trucks under the locomotive, the engine should be running to supply air under pressure to the traction motors. Air discharged from the motors will help prevent overspray from entering the motors. Care should be exercised to direct spray away from any motor openings.

A wetting agent and an alkaline solution type cleaner can be used on the truck. Spray wetting agent over truck surfaces and let it remain for 10 to 15 minutes. Then using steam and an alkaline solution in a mixing gun, thoroughly spray entire truck assembly. Rinse entire assembly with hot water.

TRUCK REMOVAL

The trucks may be removed from the locomotive using an overhead crane or jacks to raise the locomotive, or by use of a drop table.

Before attempting truck removal, the safety interlocks or side bearing clips must be released. These devices are attached to the underside of the carbody underframe and lock into recesses provided in the truck bolster. Remove all other connections

between the trucks and carbody such as air brake equipment, sanding equipment, traction motor cabling, hand brake chains, and speed recorder drive.

When removing only one truck it will be necessary to raise the entire locomotive until the carbody center bearings clear the truck bolster bearings to prevent bearing damage.

When jacks are used to raise the locomotive, ensure that all jacks are raised equal amounts. Unequal jacking may cause the carbody to be sprung out of shape. The locomotive should be supported on blocking located under the center sills near the jacking pads. Certain switcher models may require that the blocking be placed under the coupler pockets to allow side removal of trucks.

TRUCK DISASSEMBLY

The following general disassembly procedures can be followed for all trucks covered by this instruction. Since all models are covered in these procedures, some items may not be applicable in all cases.

The truck may be disassembled using one of two methods. Procedure A may be used when facilities are available to invert the truck. Procedure B may be used when it is desirable to disassemble the truck while in the upright position.

PROCEDURE A

1. Remove center bearing dust guard and wear plates. Wipe oil from enter bearing and drain oil from traction motor support bearing.
2. Remove individual items such as brake cylinders, rigging, and piping from truck.

CAUTION

Before turning truck to an upside down position, wire the swing hangers to the safety straps. This will prevent hangers from swinging out when the truck is inverted.

3. Turn truck upside down using a locally fabricated turnover fixture and an overhead crane of sufficient capacity, Fig. 3. Adequate overhead clearance must be available to accommodate full length of truck. Refer to Service Data for file drawings available to fabricate turnover fixture.

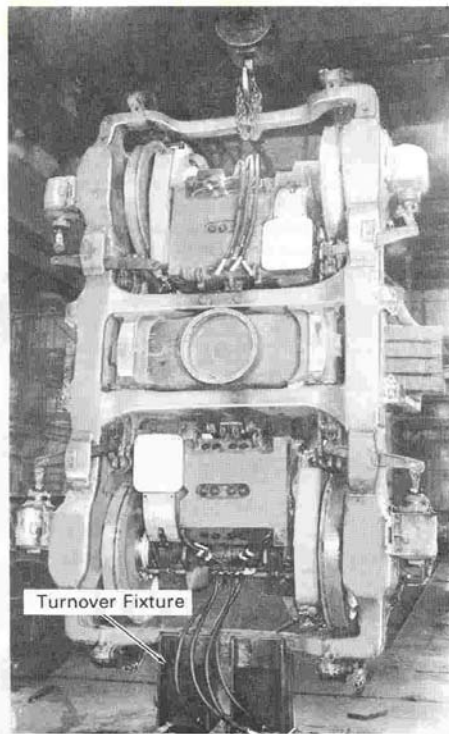

Fig.3 - Turning Over Swing Hanger Truck

4. Remove pedestal tie bars. Remove traction motor, axle, wheels, gear case, and journal boxes as a single assembly using a lifting fixture as shown in Fig. 4. Refer to Service Data for file drawing available to fabricate lifting fixture.
5. On three axle swing hanger trucks, remove bolts that secure coil spring seats and remove equalizers.
6. Remove pedestal liners, coil springs, coil spring seats, and shims.
7. Remove wires tying swing hangers to spring plank safety straps. Remove safety straps.
8. Remove swing hanger pin spacers from truck frame.

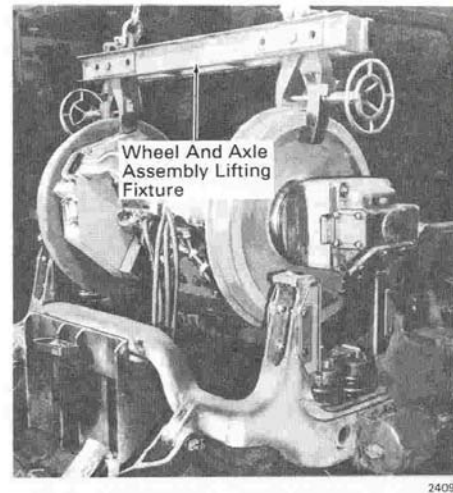

Fig.4 - Removal Of Wheel And Axle Assembly

9. Compress elliptic bolster springs slightly using fixture shown in Fig. 5. Tap out swing hanger pins. Release spring pressure and remove swing hangers and swing hangers blocks. Refer to Service Data for file drawing available to fabricate spring compressor.

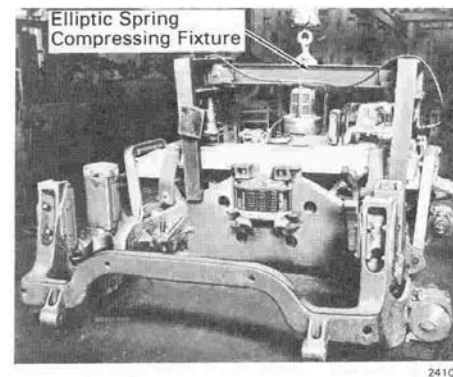

Fig.5 - Compressing Elliptic Springs

10. Remove spring plank assembly, elliptic springs, and bolster assembly.

M.I. 1501

11. Remove motor nose suspension assembly and any remaining smaller parts of the truck as desired.

PROCEDURE B

1. Remove center bearing dust guard and wear plates. Wipe oil from center bearing and drain oil from traction motor support bearing.
2. Remove individual items such as brake cylinders, rigging, and piping from truck
3. Remove traction motor gear case bolts and clips. Remove each half of gear case.
4. Remove dust guards, traction motor support bearing caps, axle guard, and outer bearing half.
5. Apply lifting chains to bails at nose suspension side of traction motor. Connect lifting hoist to chains.
6. Remove traction motor suspension pin keeper bar to allow keeper pins to drop down.
7. Lift motor to compress rubber nose pack. With the rubber nose pack compressed, insert temporary blocks about 19 mm (3/4") thick between the nose pack holder and mounting bolts as shown in Fig. 6.

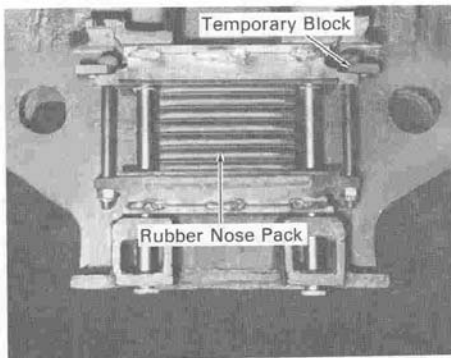

Fig. 6 - Compressing Nose Suspension Assembly

8. Lower motor a small amount to free nose suspension assembly. Remove suspension assembly from truck frame.

CAUTION

Use care when lifting motor so that support bearings will not fall and be damaged. It is recommended that a pinion protector be applied to prevent damage to pinion after motor is removed.

9. Hoist motor and allow it to rotate on axle until lower lip of support bearing will clear axle, Fig. 7. The motor assembly may now be lifted clear of the axle.

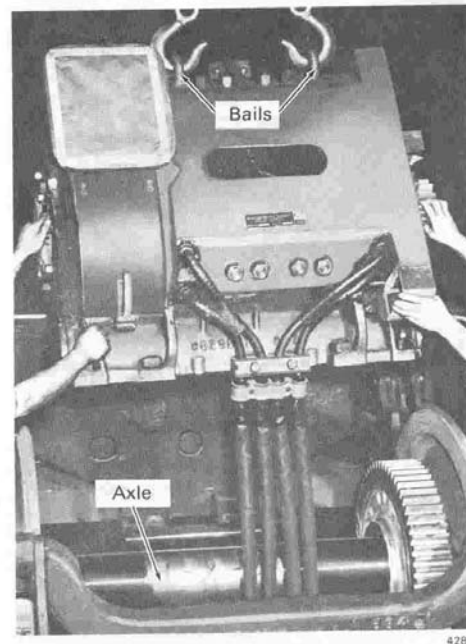

Fig. 7 - Removing Traction Motor From Truck

10. Remove pedestal tie bars, spring plank safety straps, and swing hanger pin spacers.
11. Compress elliptic bolster springs slightly by placing jacks under spring plank. Tap out swing hanger pins and remove swing hangers and swing hanger blocks. Lower spring plank assembly, elliptic springs, and bolster.
12. Lift truck frame from wheel and axle assemblies.
13. On three axle swing hanger trucks, remove bolts that secure coil spring seats and remove equalizers.

14. Remove pedestal liners and any remaining smaller parts of the truck as desired.

TANK CLEANING OF INDIVIDUAL TRUCKS

When the truck assembly is removed from the locomotive, the traction motors, wheels, gears, axles, journal boxes, brake cylinders, phenolic or composition wear plates, and slack adjuster guides should be removed if the truck is to be immersed in a cleaning tank containing an alkaline solution.

After removal of the above components, the truck frame, bolster, and spring plank may be immersed in the cleaning solution. After allowing sufficient time to assure removal of all foreign material, the assemblies should be removed and rinsed with hot water. Brake slack adjuster screws should be greased immediately to prevent seizing.

INSPECTION AND RECONDITIONING

Make a thorough inspection of the truck frame and bolster for the following items and recondition if necessary.

GENERAL

BROKEN OR CRACKED MEMBERS

Inspect entire truck frame for breaks or cracks. Perform magnetic particle inspection at any areas suspected of being cracked.

Breaks or cracks must be repaired by welding with AWS E-7016 electrode. If the broken section can be removed or straightened, it is permissible to weld it back into place after preparing the joint to obtain a 100% section of weld with reinforcement as shown in Fig. 8.

Broken cast sections may be duplicated with a like shape made from MS-4361 steel, and welded to the truck frame.

All welds made on broken or cracked sections should be magnetic particle inspected after welds have cooled to below 204° C (400° F).

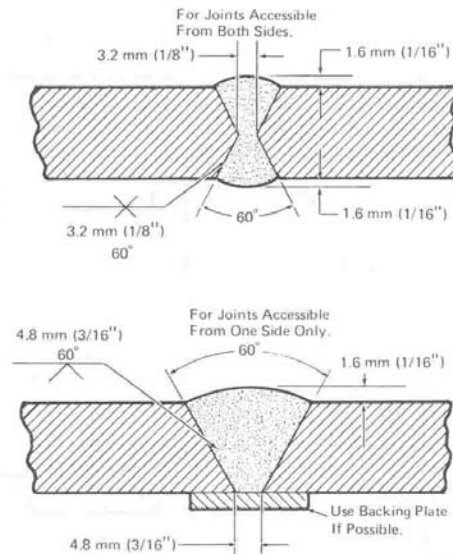

Fig.8 - Preparing Joints For Welding

BENT SECTIONS

Bent sections may be straightened either cold or after the application of heat. Before straightening any bent section, determine what effect the straightening will have on the adjoining sections. Jacks, turnbuckles or fixtures designed for straightening members will expedite the straightening of bent sections, Fig. 9.

WORN SPOTS

The truck frame should be checked for worn spots in areas other than those subject to normal wear. Special attention should be given to the swing hanger support bosses. A bent swing hanger often causes abnormal wear to one surface or the other. Loose brake levers may cause wear within the clevis slots. Springs may have to be renewed due to excessive wear of the spring seats.

Worn spots can be repaired by building up the affected area with weld using an AWS E-7016 electrode. After welding operation is complete grind the area smooth to match its original form.

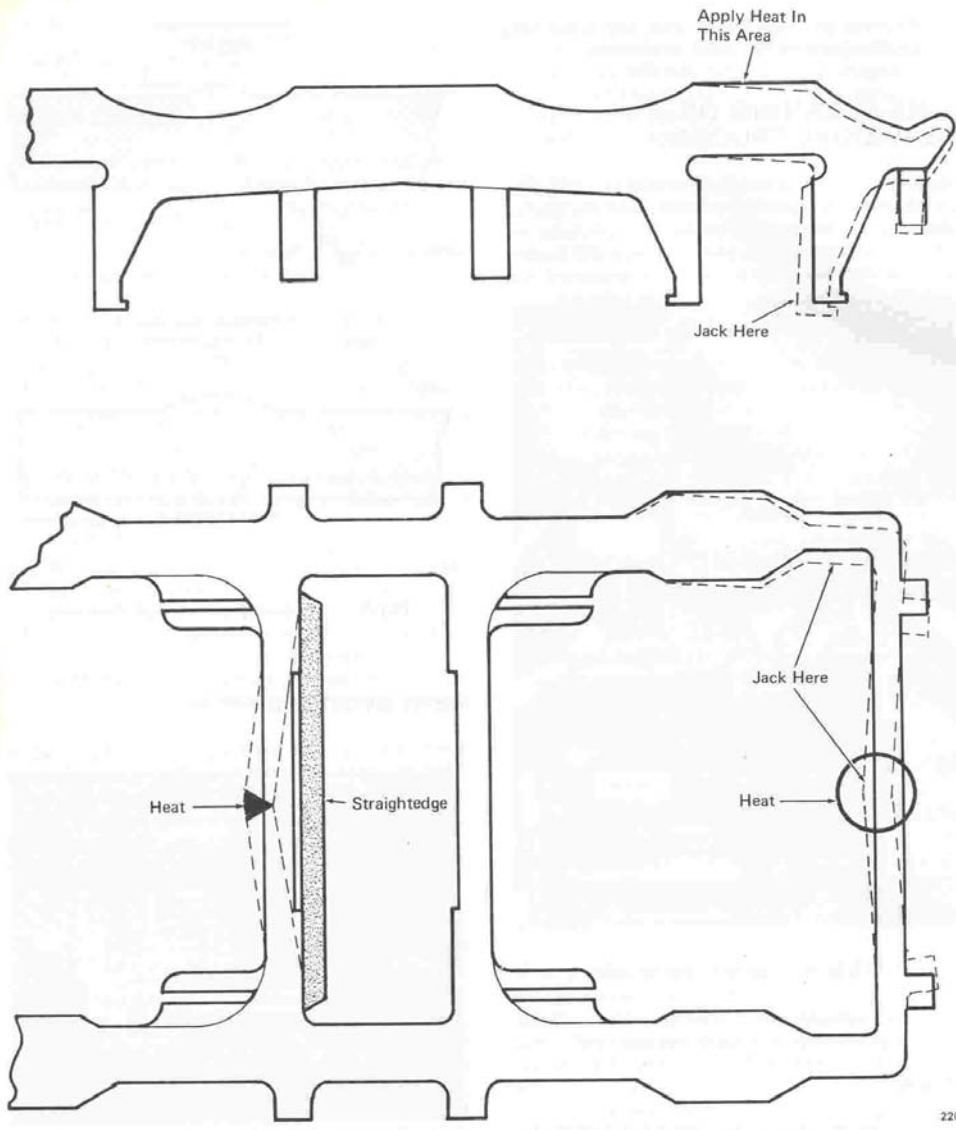

22000

Fig.9 - Straightening Bent Sections

ELONGATED OR OVERSIZE HOLES

Drilled holes elongated by wear due to loose bolts, pins, sleeves or bushings, should be brought back to normal size as determined by comparison with similar locations on a truck in good condition. The holes should not be worn more than 1.19 mm (3/64") on the radius of the supporting side or 2.38 mm (3/32") on the diameter.

Holes which are beyond the above tolerances can be reconditioned by either ring or plug welding. Holes which are too small to permit proper manipulation of the welding electrode should be drilled oversize to permit proper access for the electrode. The hole should be redrilled to proper size after completion of the welding.

WORN BUSHINGS

Bushings worn 2.38 mm (3/32") or more on the diameter should be replaced with new bushings. Where bushings are paired to carry a single load, both of the bushings should be replaced if one bushing is worn sufficiently to warrant its replacement.

Worn bushings can be pressed out. After the bushing is removed inspect the drilled hole in the frame for wear or an out-of-round condition. Holes found unsuitable for a new bushing can be reconditioned by ring welding and then drilling to accept the new bushing. Holes which are only slightly oversize may be shrunk by applying a band of heat parallel with the drilled hole.

DAMAGED THREADS

All threaded holes should be checked and retapped if required. If the threaded holes cannot be reconditioned by retapping they should be plug welded, redrilled and tapped. An alternate method of reclaiming unsatisfactory threaded holes is to retap them to accommodate an oversize bolt.

BROKEN OR BENT STUDS

Replace any broken or bent studs with studs which are in satisfactory condition.

MISSING PARTS

Make a thorough inspection to see that all the necessary parts are intact. Special attention should be given to wear plates, cotter keys, washers, bushings, studs, brake guides, and brake pins.

BOLSTER

The bolster, Figs. 10 and 11, is a steel casting used to transfer the locomotive weight to the truck frame. As previously explained, the truck bolster center bearing mates with the locomotive underframe center bearing. The switcher bolster is an integral part of the truck frame.

Some early four wheel swing hanger truck bolsters were manufactured with two 38 mm (1-1/2") wide slots at the top of the center plate receptacle ring. These slots were cut 4.8 mm (3/16") below the surface which contacts the dust guard boot. To maintain a dust seal, these slots must be built up with weld and ground smooth on the inner edges to prevent cutting the dust guard boot.

The vertical height from the elliptic spring seat to the center plate on the four wheel swing hanger truck should be 366.7 mm (14-7/16") to 376.2 mm (14-13/16"). If this dimension is 360.4 mm (14-3/16") to 366.7 mm (14-7/16") the bolster may be used but must be coded for identification when assembling the truck so that a 6.4 mm (1/4") thick shim can be applied between the swing hanger and the lower bearing block to compensate for the height deviation. If not corrected, this deviation will result in less clearance between the truck frame and the underframe and possibly cause interference.

The vertical height from the bolster side bearing to the center plate on the four wheel swing hanger truck should be maximum 109.5 mm (4-5/16") to minimum 104.8 mm (4-1/8"). If the height exceeds 109.5 mm (4-5/16") the side bearing can be machined or ground to within limits providing the side bearing section will not be less than 15.9 mm (5/8").

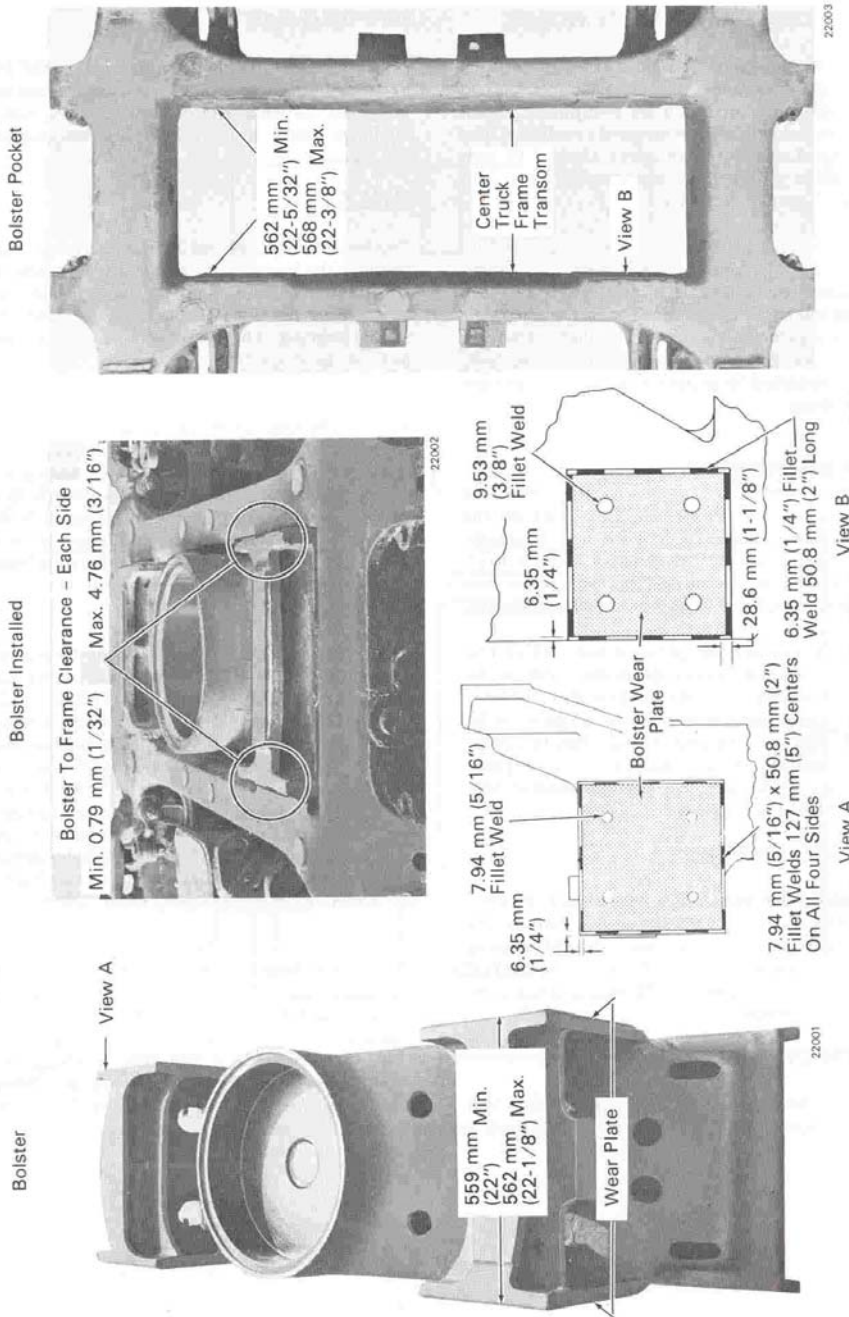
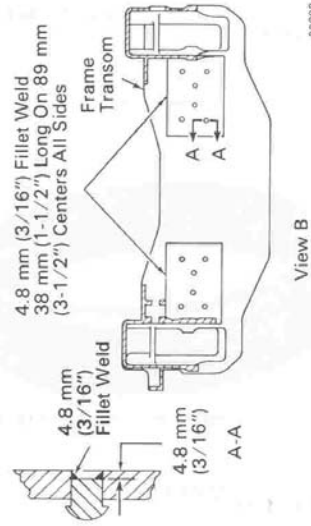
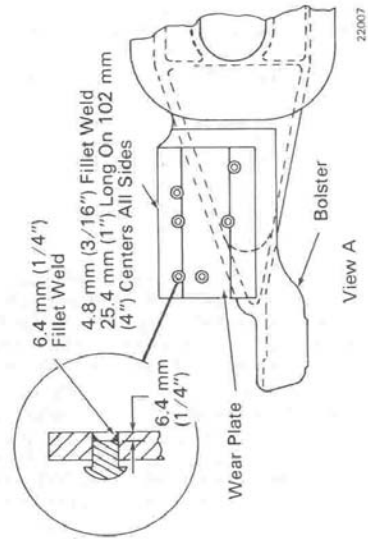
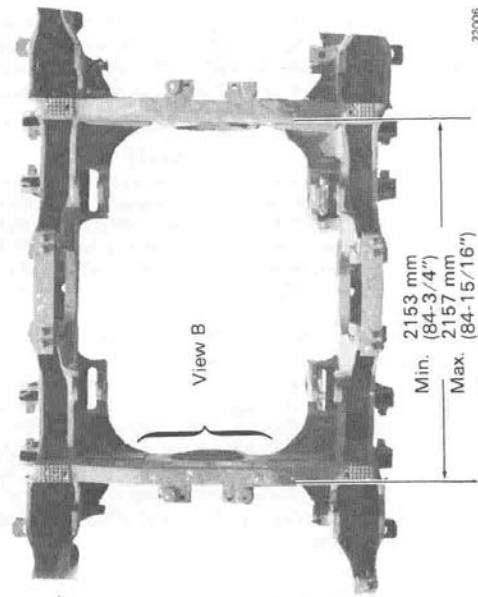
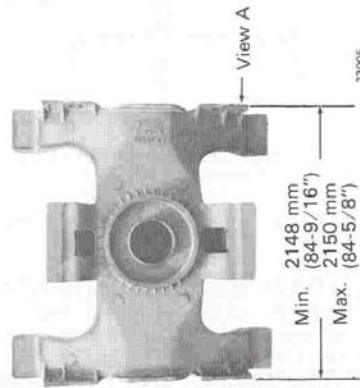

Fig.10 - Four Wheel Swing Hanger Frame And Bolster Wear Plates

Clearance Between Bolster And Frame With Bolster Installed:

Per Side

Min. 1.6 mm (1/16")
 Max. 4.8 mm (3/16")



M.I. 1501

Fig. 11 - Six Wheel Swing Hanger Frame And Bolster Wear Plates

M.I. 1501

CENTER BEARING DUST GUARD

A dust guard, Fig. 12, seals the bolster and underframe center bearings and prevents the entrance of moisture and dirt. The dust guard recess at the top of the center plate receptacle must be free of nicks and burrs which might cut or damage the dust guard boot.



Fig.12 - Center Bearing Dust Guard

FRAME AND BOLSTER WEAR PLATES

The wear plates on the truck frame and bolster wear as a result of movement between these surfaces. If the clearance exceeds the limits given in Figs. 10 and 11, either the bolster or truck frame wear plates or both should be replaced. The wear plates and their welds should be inspected using the magnetic particle method of inspection. Generally, residual magnetism in these truck parts is sufficient to provide an indication when the inspection particles are applied to their surfaces. The wear plates can be removed by grinding or chipping off the fillet welds that secure the plates. If one wear plate is removed, the wear plate at the similar location on the other side of the truck frame or bolster should be removed, as these plate surfaces should be parallel within 0.79 mm (1/32"). The replacement wear plate should conform to the specifications of the original plate.

Original wear plates applied to the bolster, and the bolster and frame transom, on six wheel swing hanger trucks, were applied using 3/4" x 2" round head rivets. Replacement wear plates should be applied by tack welding as shown in Fig. 11. The riveted wear plates can be removed by drilling into the flat head of the rivet with a 7/8" drill. After the wear plate has been removed, drive the wear plate rivets below the mounting pad surface and secure in position with a fillet weld, Fig. 11. This will seal the holes and provide a backing for a plug weld of the existing holes in the replacement wear plate.

Prior to the application of the new plate be sure that the mating surfaces of the parts to be welded are clean, smooth and flat. Use AWS E-7016 or E-7018 electrodes or equivalent for SAE 1060 heat treated steel wear plate.

NOTE

In some applications other types of wear plates may be used. For manganese wear plates, use AWS E-Fe Mn-A electrode and for SAE 1095 heat treated steel wear plates, use AWS E-310-16 stainless steel electrode or AWS E-Fe Mn-A electrode.

During welding, the part should be held in the correct position and in full contact against its mating part. Care should also be taken that fillet welds are not higher than the wearing surface of the plates. Grind down any weld material that overlaps onto the surface of the wear plate. Wear plates which have holes in the plate for welding should have the area of holes welded first, as this will help to ensure contact at the center of the plate and prevent warping of the plate.

SIDE BEARING WEAR PLATES

This side bearing surfaces on the bolster are designed to mate with similar side bearings mounted beneath the carbody underframe as indicated in Fig. 13.

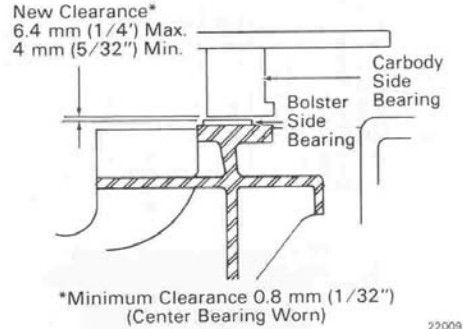

Fig.13 - Side Bearing Wear Surfaces

A clearance is provided between the truck bolster side bearings and the carbody side bearings during normal operation. Side bearings are designed to prevent excessive tilting or leaning of the locomotive but are not designed to carry a continuous load.

Side bearing clearance on a new assembly is 4 mm (5/32") minimum to 6.4 mm (1/4") maximum. The minimum side bearing clearance is 0.8 mm (1/32"), as shown in Fig. 13. (The No. 2 truck on the switcher locomotives has a 9.5 mm [1/8"] minimum and 12.7 mm [1/2"] maximum limit.)

Any time the side bearing clearance approaches the minimum limit the bolster center bearing wear plate should be checked for wear. Side bearings should be flat and in the same plane within 0.8 mm (1/32") as the side bearing on the opposite side of the truck. If bearing is misaligned or is uneven, it may be repaired by building up the surface with weld and grinding to a proper level.

The old wear plates can be removed by grinding off the fillet welds around the plate. New plates should be of mild steel material 6.4 mm (1/4") or 9.5 mm (3/8") thick depending on the thickness required to give the proper clearance.

Apply new wear plates using a 6.4 mm (1/4") fillet weld 76 mm (3") long on each end and two evenly spaced 51 mm (2") long fillet welds on each side of the four wheel swing hanger truck side bearing wear plate. The six wheel swing hanger truck side bearing should have a 51 mm (2") long 6.4 mm (1/4") fillet weld on the ends and two 6.4 mm (1/4") fillet welds 51 mm (2") long and 178 mm (7") apart on the sides. The switcher side bearing wear plates are welded only on the side next to the center bearing with 9.5 mm (3/8") fillet welds 51 mm (2") long and 152 mm (6") apart.

CENTER BEARING WEAR PLATES AND WEAR RING

The bolster center bearing on each truck supports half the weight of the locomotive. Also, the bolster center bearings transfer motive force to the locomotive carbody. The load on these parts and the relative movement between them will cause the parts to wear.

As mentioned previously, side bearing clearance close to the limit is an indication of wear at the center bearing wear plate. The rebuild and condemning limits of the center bearing wear plate are shown in Fig. 14. The thickness of the wear plate should be checked whenever the plate is accessible. When the plate reaches the condemning limit, it should be replaced by a new plate. If the thickness of the plate is greater than the rebuild limit, it may be re-used. However, if the thickness is less than the

rebuild limit, it should be replaced with a new plate. The purpose of the rebuild limit is to ensure ample thickness of the plate to allow for wear until the next inspection, without exceeding the condemning limit.

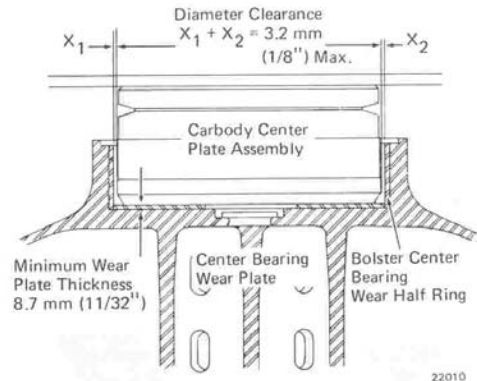

Fig.14 – Bolster Center Bearing Clearance

The outside diameter of the carbody center plate bushing and the inside diameter of the bolster center bearing wear half ring should be checked to determine the total clearance between them.

The recommended clearance is shown in Fig. 14. The maximum clearance between these parts is 3.2 mm (1/8"), as indicated.

Center wear plates and wear rings, except for the switcher wear plate, are made of 9.5 mm (3/8") thick Nylatron or laminated phenolic. Switcher wear plates are 13 mm (1/2") thick when new.

Check the center bearing area of the bolster to make sure there are no cracks or voids which might allow lubricating oil to leak out. This is especially important when working with a six wheel swing hanger or switcher truck because any lubricant which seeps into the center casting air duct could contribute to traction motor failure. If any cracks are found, they must be completely removed by arc air cutting, flame cutting, chipping, or grinding and a 60° "V" groove provided for welding. Weld the crack with AWS E-7016 electrode. Peen the second weld pass and each pass thereafter to minimize distortion. Grind off excess weld metal so the surface of the center bearing plate will be flat within 0.51 mm (0.020").

M.I. 1501

After the old wear plates and wear rings are removed and the necessary repairs made, the bearing bore should be cleaned and the surfaces smoothed so they offer little resistance to the application of the new replacement half rings. Check the replacement half ring surfaces to see that they are smooth. Apply a lubricant to the outside diameter of the half rings and apply the half rings to the center bearing bore. The replacement half rings have an interference fit in the bore, so they must be forced into position in the bolster center casting. Apply so that the split line between the half rings will be 90° from the longitudinal centerline of the locomotive.

PEDESTAL LINERS

Pedestal liners, Fig. 15, are provided to absorb the wear that occurs from the relative movement

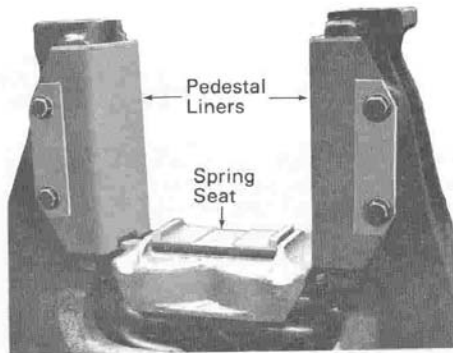

24102

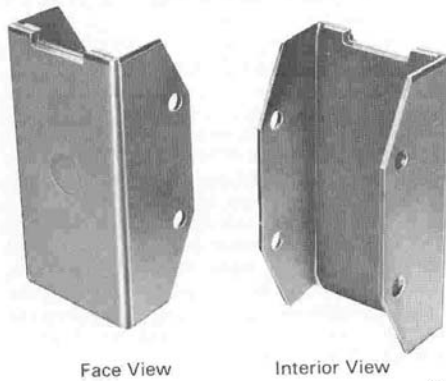

24333

Fig.15 - Notched Nylatron Pedestal Liners

between the journal box and the pedestals. For convenience of replacement, the pedestal liners are bolted to the pedestal jaw.

Nylatron pedestal liners are basic equipment on all domestic trucks. Metallic liners are available upon request. See the Parts Catalog for the correct part numbers.

During 1977 a "notched" Nylatron pedestal liner became basic replacing the previous unnotched liner. The new pedestal liner is interchangeable with the previous design.

The notch on the top edge of the liner reduces the journal spring force when the spring seat is allowed to rest on the pedestal liner during truck buildup or wheel-axle changeouts. In addition, increased groove radius at the ends of the inside corners reduces stress.

Clearance limits between the longitudinal or lateral wear surfaces, are such that in normal operation the clearance will not exceed the maximum in the period between truck reconditioning. The nominal lateral clearance between the journal box and the pedestal liner is 1.6 mm (1/16") at each side of the pedestal as shown in Fig. 16. The truck pedestal to journal box wear limits are shown in Fig. 17. If the clearances are beyond the maximum limits, the wear plates must be replaced. The wear plates must be checked for possible breaks or Nylatron cracks by visual inspection if they are to be reused.

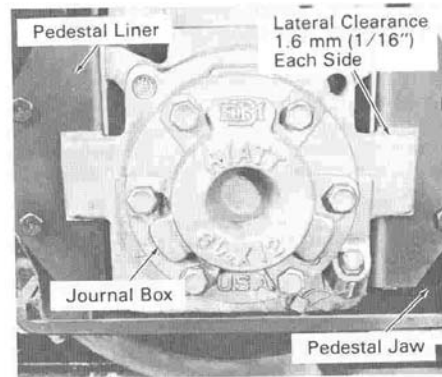

22012

Fig.16 - Pedestal Liner To Journal Box Clearance

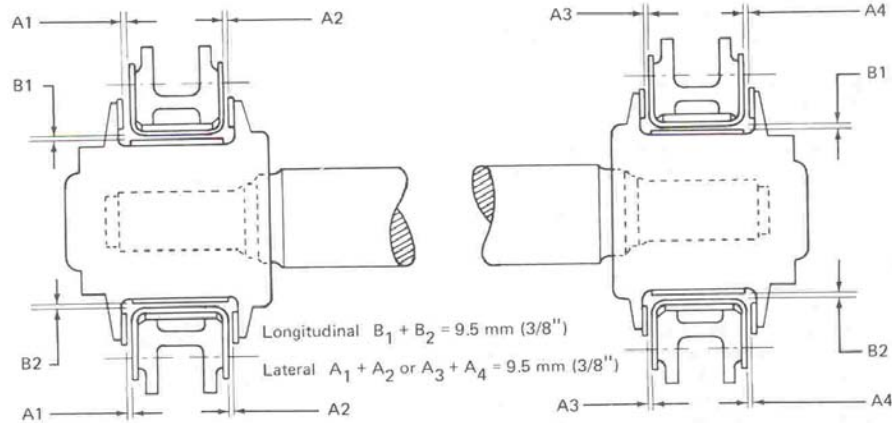

Fig.17 – Typical Truck Pedestal Liner To Journal Box Wear Limits

The clearance between the journal box and the pedestal can be measured using feeler gauges. Feeler gauges must be approximately 25.4 mm (1") wide and 205 mm (12") long. Care should be taken in making this measurement to see that the gauge is inserted adequately into the clearance and that it fits into the wearing area so a true reading is obtained. All measurements should be taken with the journal boxes in the position they are in when the locomotive is stopped. No attempt should be made to shift the journal boxes on the axle while the weight of the locomotive is supported by the boxes.

PEDESTAL LINER APPLICATION

Inspect pedestal jaws to make certain that surfaces are smooth and free of any raised areas that might interfere with application of liners. Chamfer any sharp corners on the journal box liners, to prevent damage to pedestal liners.

WARNING

To prevent liner breakage and possible injury to personnel, apply notched pedestal liners only in pairs. This will ensure that the journal spring seats are level during truck buildup or wheel-axle changeouts.

Apply liners using a pedestal liner installation fixture, Fig.18. Refer to Service Data for file drawing available to fabricate pressing tool. When notched pedestal liners are used, the notch must be positioned next to the spring seat with the ears on the spring seat nestled into it. Liners should fit tightly on the pedestal jaw with the mounting holes mating with

Pedestal Liner
Installation Fixture

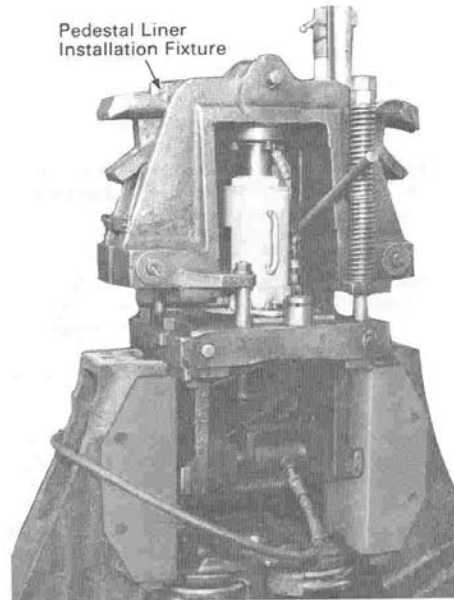

24103

Fig.18 – Pedestal Liner Application

the pedestal bolt holes and liner driving face in complete contact with the pedestal jaw. Mounting bolts should enter liner and pedestal bolt holes freely. Apply bolt and washers, torque bolts to between 237 and 305 N-m (175 and 225 ft-lbs).

NOTE

A plate type washer 9515453 is available to replace washer 106269. The plate washer spans both pedestal liner mounting bolts to reduce liner stresses.

The dimension between liner faces should be 381.28 mm (15.011") minimum to 382.85 mm (15.073") maximum on four wheel swing hanger trucks, 381.38 mm (15.015") minimum to 383.59 mm (15.102") maximum on six wheel swing hanger trucks, and 281.15 mm (11.069") minimum to 283.19 mm (11.149") maximum on switcher trucks.

On early model trucks, the pedestals were 25.4 mm (1") narrower than on current models. To compensate for this difference, a filler plate 8212026, Fig. 19, was applied between the pedestal liner and pedestal on each side of the pedestal jaw. These filler plates may be used with a new pedestal liner if desired.

COIL SPRING SEAT

A spring seat is used between the coil springs and journal box to provide a means to secure the springs to the journal box.

Shim plates are used between the spring seat and springs to maintain proper locomotive height for different weight locomotives.

A two axle locomotive using 1 016 mm (40") diameter wheels, should maintain a height from the rail to the bottom of the underframe of 1 165 mm (45-7/8"). Shimming is provided to maintain the coupler height and a reasonably equal axle load distribution on the rail. For complete information on application of shims see the applicable Maintenance Instruction.

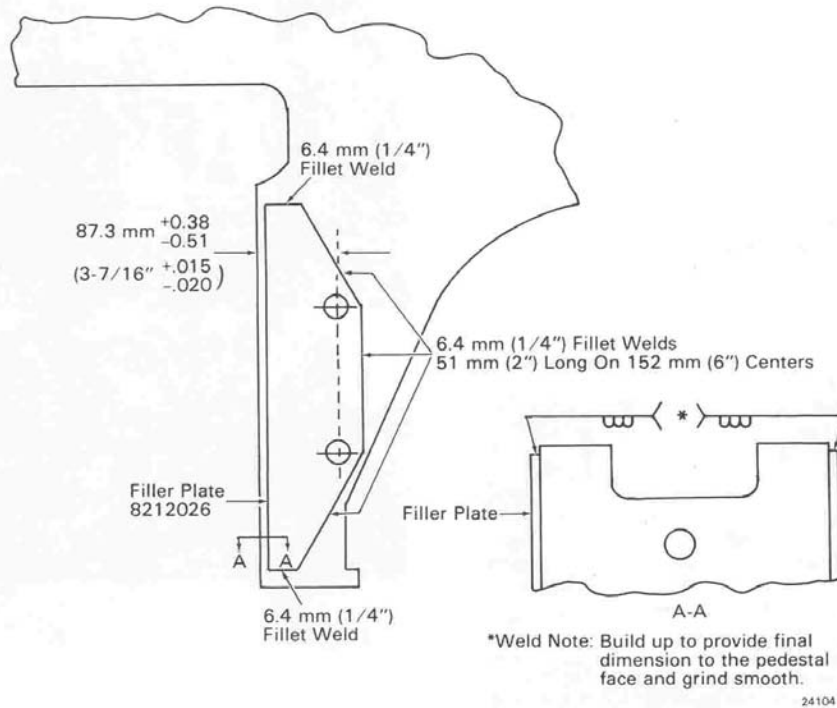

Fig.19 - Typical Pedestal Liner Filler Plate Application

Inspect all spring seats during truck reconditioning for evidence of distortion or damage. Limits for dimensions which are subject to change because of wear are shown in Fig. 20.

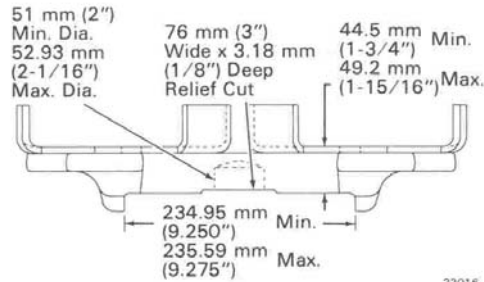

Fig.20 - Spring Seat Wear Limits

TRACTION MOTOR NOSE SUSPENSION ASSEMBLY

SUSPENSION PACKS

Each time power is applied to the traction motors, the pinion of each motor tries to ride around the axle gear, raising the motor up or pulling it down, depending on the direction of motion. This movement of the motor is arrested by securing the motor to the truck frame transom through a shock damping rubber suspension pack, Fig. 21.

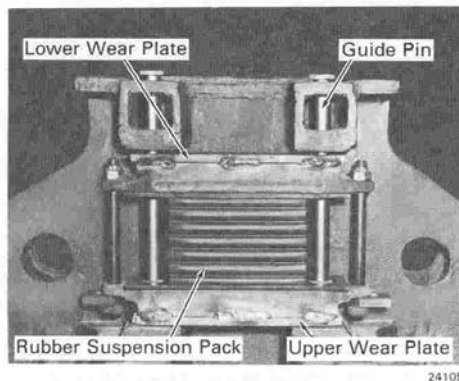

Fig.21 - Traction Motor Nose Suspension Assembly

WEAR PLATES

The wear plates on the suspension assembly are subjected to severe shocks and tremendous pressures, causing them to wear, resulting in free movement between the traction motor frame and the suspension assembly. As this movement increases, due to wear, the severity of the shocks increases, especially during the rapid changes of torque caused by wheel slip.

To obtain maximum cushioning effect from the suspension pack, wear plates should be periodically replaced to ensure there is not more than 6.4 mm (1/4") free movement in the traction motor nose suspension. If the wear plates, which are 12.7 mm (1/2") thick when new, are worn enough to permit more than the 6.4 mm (1/4") free movement, or if the wear plates are worn more than the limits given in Fig. 22, the suspension pack should be removed and the wear plates replaced.

The upper wear plate is identical to the lower wear plate, which has a minimum limit of 11.11 mm (7/16"). The lower wear plate may be moved to the upper position if it is still within the 10.32 mm (13/32") upper wear plate limit.

The old wear plate can be removed from the spring pack by grinding or chipping off the tack welds holding it. The new wear plate should conform to the dimensions of the original plate.

The manganese steel wear plate should be applied to the suspension pad with 9.5 mm (3/8") fillet welds 57.2 mm (2-1/4") long, spaced 95.3 mm (3-3/4") apart. When welding manganese steel wear plates use an AWS E-Fe Mn-A welding electrode.

NOTE

Early models used a coil spring type suspension pack and should be updated to the rubber suspension pack. The rubber suspension pack is interchangeable with the coil spring type and uses the same suspension pack holders, wear plates, pins and bolts.

MOTOR NOSE SUSPENSION LUGS

The lugs on the truck frame transom that support the traction motor suspension assembly are subject to wear due to the chafing of the suspension assembly. The maximum dimension between these surfaces in 28.58 mm (12-1/8") as shown in Fig. 22. If this limit is exceeded, it will be necessary to build

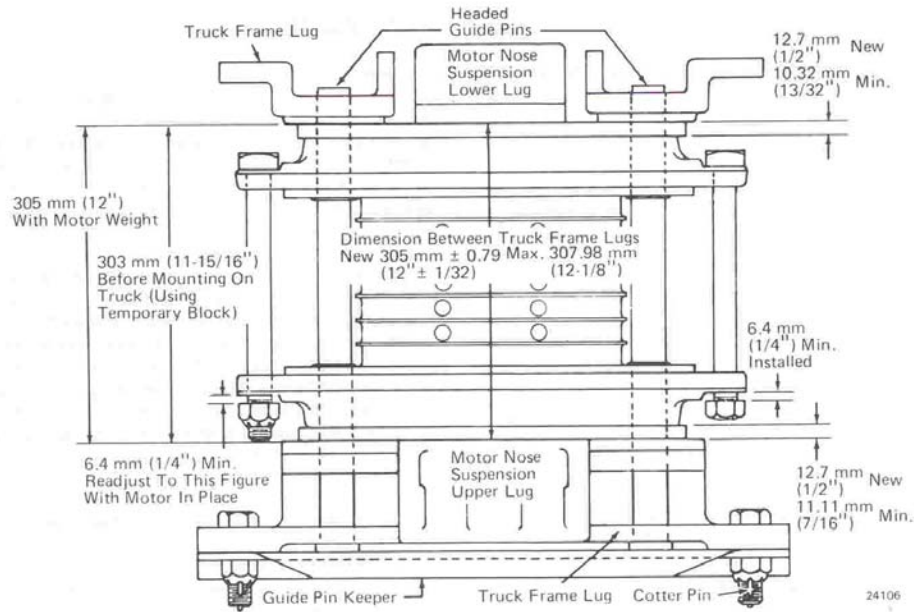

Fig.22 - Traction Motor Nose Suspension Wear Plates

up the lug faces, by welding and machining or grinding, to obtain the original dimension of 305 mm (12") ± 0.79 mm (1/32"). The ground or machined surfaces of the lugs should be in the same plane within 0.79 mm (1/32") and contacting at least 75% of the area on each lug when using a straightedge for measuring.

Current practice is to install a 4.76 mm (3/16") thick manganese steel wear plate on each of the four truck frame suspension lugs. If manganese wear plates are used on the suspension assembly, they should also be used on the suspension lugs. This will reduce wear at these points and allow an extended period between rework. The wear plates are applied to the lugs with a 4.76 mm (3/16") fillet weld using an AWS E-Fe Mn-A welding electrode. Weld the plate on three sides as shown in Fig. 23. After the wear plates are applied, the surfaces must still be in the same plane and the dimension between the upper and lower lugs must be 305 mm (12") ± 0.79 mm (1/32").

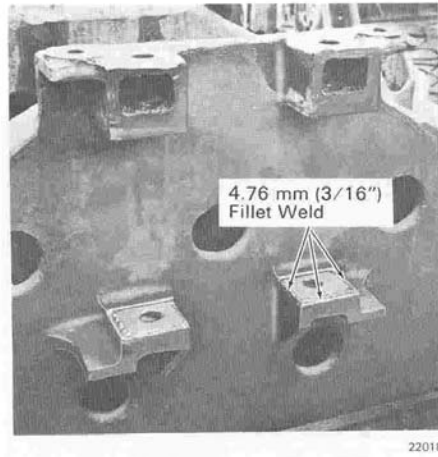

Fig.23 - Truck Frame Motor Nose Suspension Lugs

The guide pin holes in the frame lugs should be checked for size. The holes are drilled to a nominal 33.34 mm (1-5/16") diameter when new. If they become worn or elongated by 2.38 mm (3/32") or more, they must be ring or plug welded and redrilled to correct dimension. An optional method of repairing the guide pin holes is to drill the worn holes to 47.63 mm ± 0.051 mm (1.875" ± 0.002") and press in internal tension bushing 8340530. The guide pins are 31.75 mm (1.250") in diameter when new, renew when worn to 30.99 mm (1.220").

NOTE

Motor nose suspension assemblies (except for D29CC applications) manufactured after September 1978, are equipped with headed guide pins 9334249. The advantage of the new guide pin is its longer length which completely fills the upper guide hole in the truck frame lug. This reduces the tendency of the pin to wear the guide hole to an irregular shape with the subsequent need to drill out and bush the hole.

The new guide pin has a formed head on one end to prevent the pin from working its way upwards out of the guide holes in the truck frame. As with the old pin, the guide pin keeper prevents the pin from falling out of the guide holes. Use of the new pin requires the removal of the small metal cover plate that is welded over the upper guide hole. The cover plate can be removed by air carbon arc gouging, and grinding afterwards to ensure that the edge of the hole is free of projections. Both cover plates should be removed and the new pins applied in pairs. Once this modification is made, use of the old style pin is not advised as there will be nothing to prevent the pin from working upwards out of the guide holes.

TRUCK FRAME PEDESTAL REPAIR

WHEEL BASE SPACING

The wheel base spacing is the measured distance between the transverse centerline of the truck and transverse line between the jaws of the pedestals or the dimension between the axle centerlines. These dimensions are shown in Figs. 24, 25, and 26.

It is first necessary to locate the truck frame transverse centerline or the middle axle centerline to obtain the wheelbase spacing. This can be done by centering a straightedge between the machined surfaces of the transom on a four wheel truck or by measuring between the middle pedestals on a six wheel truck.

The wheelbase dimension on four wheel trucks is obtained by placing a straightedge along the face of the pedestal jaw and measuring from this straight-edge to the transverse centerline. To this dimension add 1/2 the distance measured between the pedestal jaws. On six wheel trucks, measure the distance between the pedestals as shown in Fig. 27. The wheelbase figures obtained should be within the limits given in Figs. 24, 25, and 26. The transverse centerline of the pedestals or axle centerline must be parallel to the transverse centerline of the truck within 0.79 mm (1/32").

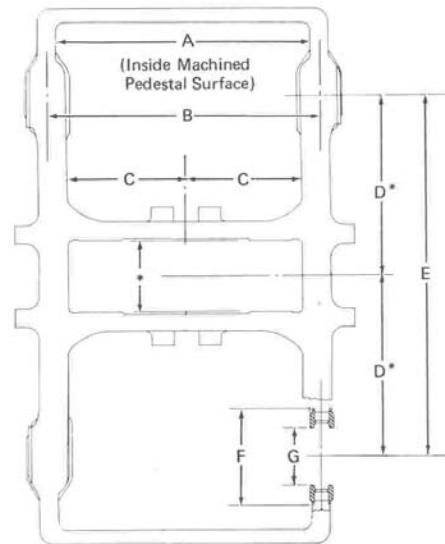

*Parallel within 0.79 mm (1/32")

	Dimensions	
	Metric	Standard
A	1 842.29 mm ± 1.59 mm	72-17/32" ± 1/16"
B	2 019.30 mm ± 1.59 mm	79-1/2" ± 1/16"
C	921.15 mm ± 0.79 mm	36-17/64" ± 1/32"
D	1 371.60 mm ± 3.18 mm	54" ± 1/8"
E	2 743.20 mm ± 6.35 mm	108" ± 1/4"
F	663.58 mm + 0 - 0.40 mm	26-1/8" + 0 - 1/64"
G	427.04 mm + 0 - 0.79 mm	16-13/16" + 0 - 1/32"

22019

Fig.24 - Four Wheel Swing Hanger Truck Frame Dimensions

TRANSVERSE PEDESTAL SPACING

The transverse pedestal spacing refers to the dimension between the inside machined surface of

pedestal jaws on opposite sides of the truck or between the inside machined surface of the pedestal jaw and the longitudinal centerline of the truck. The dimensions for the individual trucks are shown in Figs. 24, 25, and 26. The transverse measurements may be made as shown in Fig. 27. The pedestals may lean in or out, providing both pedestals of each set lean in the same direction and are within the plus or minus tolerance allowed from the longitudinal centerline of the truck frame to the inside face of the pedestal.

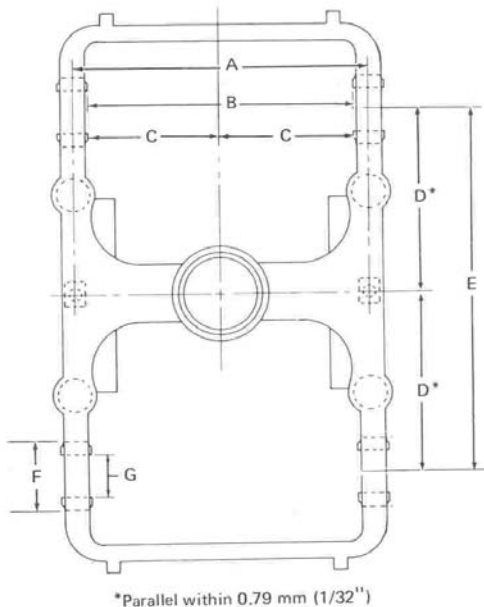

Dimensions		
	Metric	Standard
A	2 006.60 mm ± 1.59 mm	79" ± 1/16"
B	1 810.54 mm ± 1.59 mm	71-9/32" ± 1/16"
C	905.27 mm ± 0.79 mm	35-41/64" ± 1/32"
D	1 219.20 mm ± 3.18 mm	48" ± 1/8"
E	2 438.40 mm ± 6.35 mm	96" ± 1/4"
F	469.90 mm ± 0.40 mm	18-1/2" ± 1/64"
G	301.63 mm ± 0.79 mm	11-7/8" ± 1/32"

Fig.25 - Four Wheel Switcher Truck Frame Dimensions

Pedestals which do not conform to the dimensional limits can be corrected by straightening the truck frame, hot or cold.

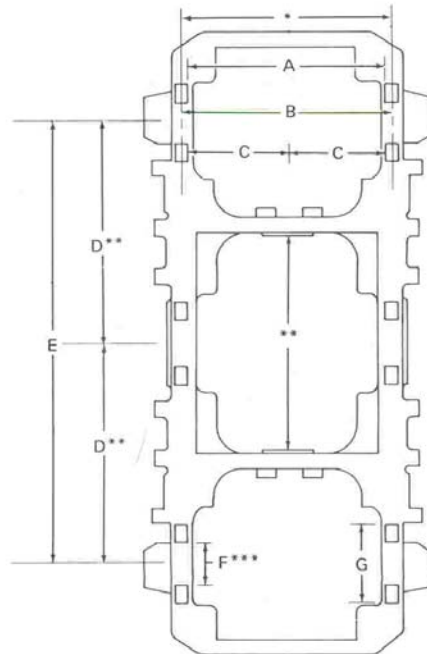

*Parallel within 0.40 mm (1/64") in 609.6 mm (24")
 **Parallel within 0.79 mm (1/32")
 ***Older model dimension
 396.88 mm ± 0.25 mm
 (15-5/8" ± 0.010")

	Dimensions	
	Metric	Standard
A	1 823.24 mm ± 1.59 mm	71-25/32" ± 1/16"
B	1 993.90 mm ± 1.59 mm	78-1/2" ± 1/16"
C	911.62 mm ± 0.79 mm	35-57/64" ± 1/32"
D	2 146.30 mm ± 3.18 mm	84-1/2" ± 1/8"
E	4 292.60 mm ± 6.35 mm	169" ± 1/4"
F	395.29 mm ± 0.40 mm	15-9/16" ± 1/64"
G	723.90 mm ± 0.40 mm	28-1/2" ± 1/64"

22021

Fig.26 - Six Wheel Swing Hanger Truck Frame Dimensions

LONGITUDINAL PEDESTAL SPACING

The longitudinal pedestal spacing refers to the distance between the inside surfaces of the pedestal jaws on the same side of the truck as indicated in Figs. 24, 25, and 26, for individual truck frames. Incorrect pedestal spacing is caused by a bent frame or bent pedestals, either of which requires straightening to obtain the correct pedestal spacing.

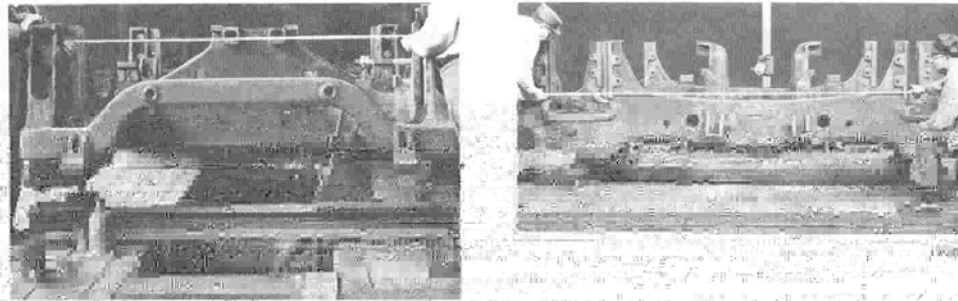

Fig. 27 - Measuring Wheelbase And Pedestal Spacing

HORIZONTAL PEDESTAL ALIGNMENT AT THE BASELINE

The horizontal pedestal alignment at the baseline is the relationship from one pedestal jaw to any other pedestal jaw on the track frame, as indicated in Fig. 28.

This alignment can be determined by measuring from a straightedge tool or wire spanning the pedestals, as shown in Fig. 28. Misalignment may be no more than 3.18 mm (1/8") above or below the pedestal baseline. A condition in excess of this may only be corrected by straightening the track frame.

Spring seat centerlines may be misaligned 3.18 mm (1/8") with respect to pedestal centerline and 1.58 mm (1/16") with respect to each other.

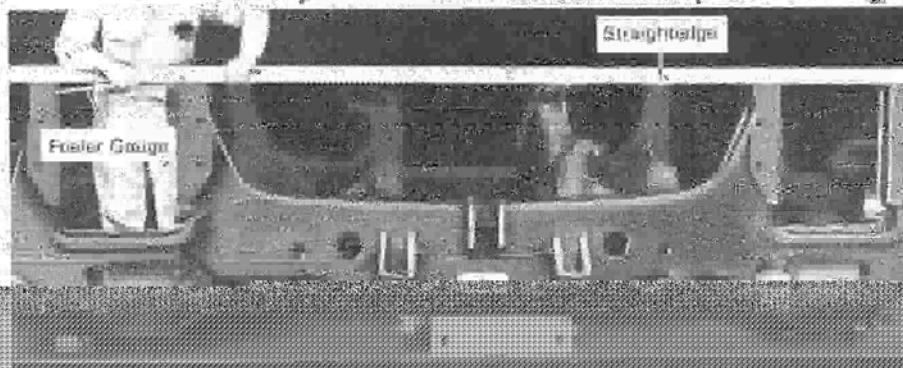
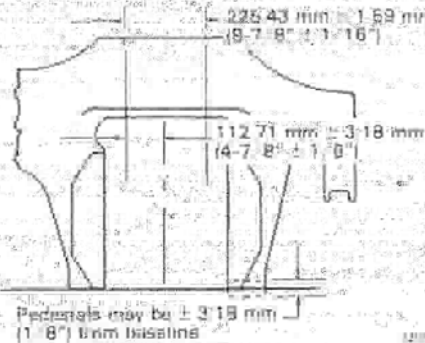

Fig. 28 - Pedestal Base Horizontal Alignment

**LOCATION OF JOURNAL BOX
COIL SPRING SEATS**

The centerline of the coil spring retainer seats should be held within 3.18 mm (1/8") on either side of the centerline of the truck pedestal opening, as indicated in Fig. 28. The coil spring seat location should be checked for alignment when any rework is done on the pedestals. If the misalignment is more than 3.18 mm (1/8") it may be corrected as indicated in Fig. 29. A section of each of the two spring seat flanges is flame cut and spread to accept the coil spring on the new center. Then spread the flanges to their new position and reweld them as illustrated. Grind the new welds smooth so that no high spots remain which would cause localized loading on the coil springs.

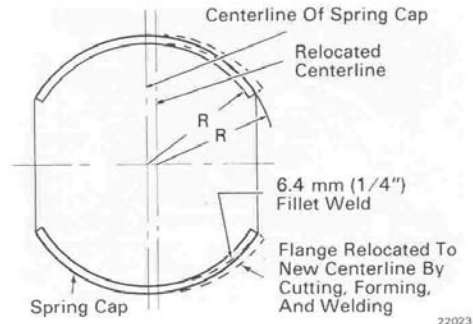
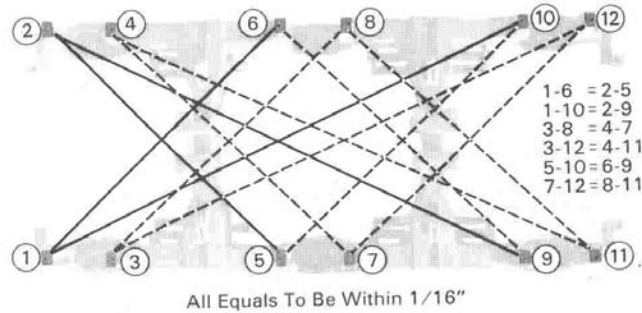

Fig.29 - Relocation Of Spring Seat Centerline

TRAMMING OF TRUCKS

The truck pedestals are trammed to determine if they are in correct alignment with each other, that is

to determine if the distance between pedestals is equal or within the allowable limits. The diagrams shown in Fig. 30 indicate which pairs of pedestals should have equal distances between them.



13027

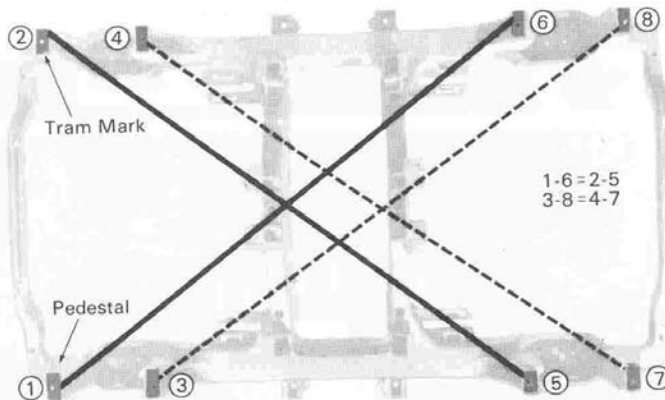

13028

Fig.30 - Truck Frame Tramming Diagrams

Tramming is accomplished by using a trammel beam as shown in Fig. 31 with the truck frame inverted on a level table or level location. In addition to the diagonals shown in Fig. 30, it may be necessary to check the tram of the pedestals both longitudinally and transversely as indicated in Fig. 31.

The tram assembly is made up of two trammels attached to a wooden or metal beam of such construction that it will hold the assembly rigid. This assembly facilitates taking comparative measurements of varying lengths, which could not be done using conventional dividers. The trammels permit any distance separation on the beam so the various dimensions to be trammed can be compared.

Tram marks are made on the end or bottom of each pedestal at the time of original manufacturing inspection of the truck frame. These marks, which are small punch indentations, are placed at identical locations on each pedestal to assure an accurate comparison. They may be either 38 mm (1-1/2") from each inside face of the pedestal or on the longitudinal centerline of the pedestal just inward from the tie bar bolt hole. The important consideration is that the mark is made at an identical location on each pedestal.

A special tool shown in Fig. 32 for locating the tram marks on the pedestal can be made from File Drawing 615, which is available upon request. This tool is used to make two scribe marks at right angles

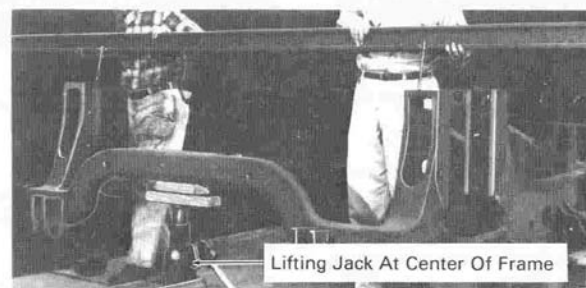

22153

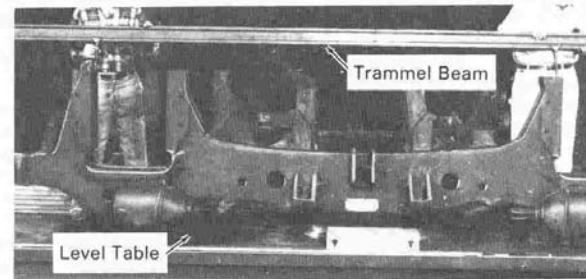

22154

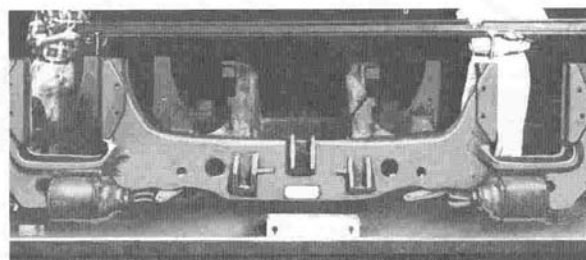

22155

Fig.31 - Application Of Trammel Beam Between Pedestals

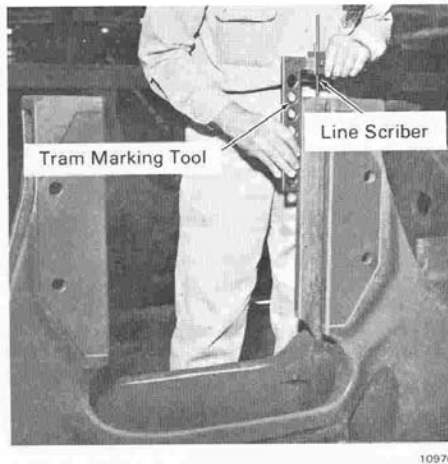

Fig.32 – Tram Marking Tool

to each other at the 38 mm (1-1/2") or other required dimension on the bottom of the pedestal. The hardened end of the scribe on the tool is placed at the intersection of the scribe lines and is lightly tapped with a hammer, to make a small indentation in the metal for the tram points. To aid in locating the tram marks, the bottom of the pedestal should first be cleaned and then coated with blue layout dye.

In the event of rework on the truck such as straightening of bent pedestals, it will be necessary to remove the old tramping mark and relocate a new mark.

The truck frame should be leveled before tramping. Support the truck frame on two small jack screws under the end pedestal spring pockets at one end of the frame and by one jack screw or hydraulic jack placed on the longitudinal centerline at the opposite end of the frame, similar to the support shown in Fig. 31. The end supported by the two jacks is raised to any convenient height, and measured at the top of the end pedestals, Fig. 33. The end pedestals at the center supported end of the frame are raised to the same height as the other end. If one pedestal cannot be raised to a height equal to that of the other pedestal, it indicates that the frame has a slight twist at the end of the lower pedestal.

Each pedestal should be checked for leaning at the inside surface and the side facing the center of the truck before tramping. The pair of pedestals opposite each other (one on each side of the frame)

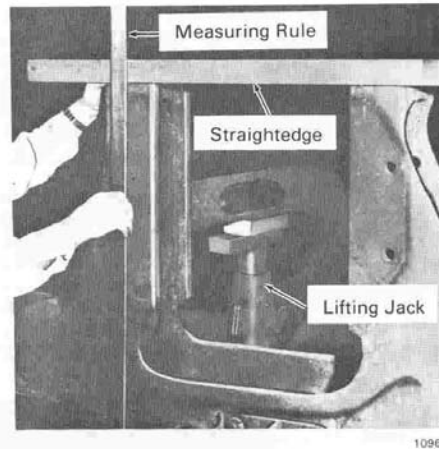

Fig.33 – Leveling Truck Frame

which are found to be square or nearly square, are used as starting points for tramping. The pedestals are checked using a straightedge and square, Fig. 34.

If the diagonal measurements shown in Fig. 30 are not equal, it will be necessary to tram the pedestals longitudinally and transversely, Fig. 31 to locate the pedestals that are out of alignment and determine how much they are out of alignment.

A typical example of the tram measurements are shown in Fig. 35. The diagonal trams 3-8, 1-6, 2-5, and 4-7 are shown to be unequal by plus 3.18 mm (1/8"), 0, plus 0.79 mm (1/32") and plus 1.59 mm (1/16") respectively. The diagonal trams are allowed a tolerance of ± 1.59 mm (1/16") so the only pedestals exceeding this limit are on the 3-8 diagonal. This indicates that pedestals 3-8 are out of alignment either longitudinally or transversely. Tramping also indicates that longitudinally all the pedestals are equal as shown by the equal "0" longitudinal measurements. Transverse tramping indicates that pedestals 7-8 are equal to pedestals 1-2, but pedestals 5-6 and 3-4 are wider than the other two pair by 1.59 mm (1/16") and 5.56 mm (7/32") respectively.

Since pedestals 3-4 are plus 5.56 mm (7/32") it accounts for the plus 3.18 mm (1/8") and plus 1.59 mm (1/16") length of the diagonal trams 3-8 and 4-7 going to these pedestals. Since 3-8 plus 3.18 mm (1/8") is twice the plus 1.59 mm (1/16") of 4-7, it can be seen that pedestal No. 3 needs to be bent inward twice as much as pedestal No. 4. If pedestal No. 3 is

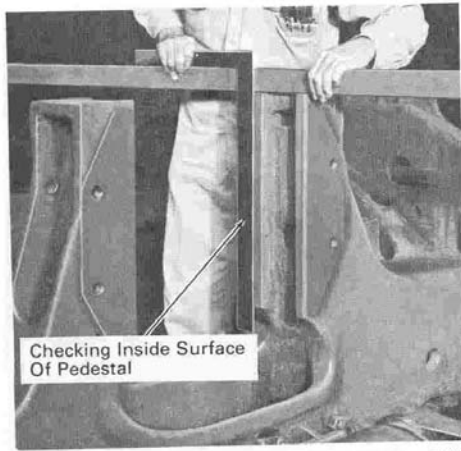

10967

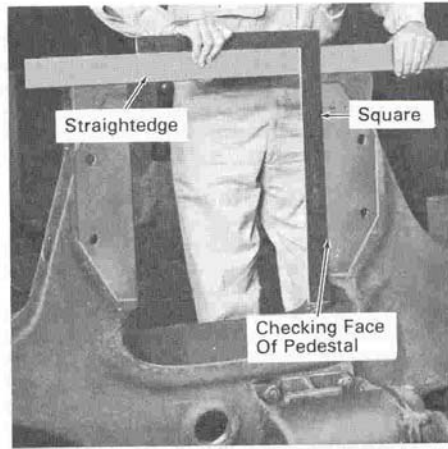

10968

Fig.34 - Checking Pedestal Squareness

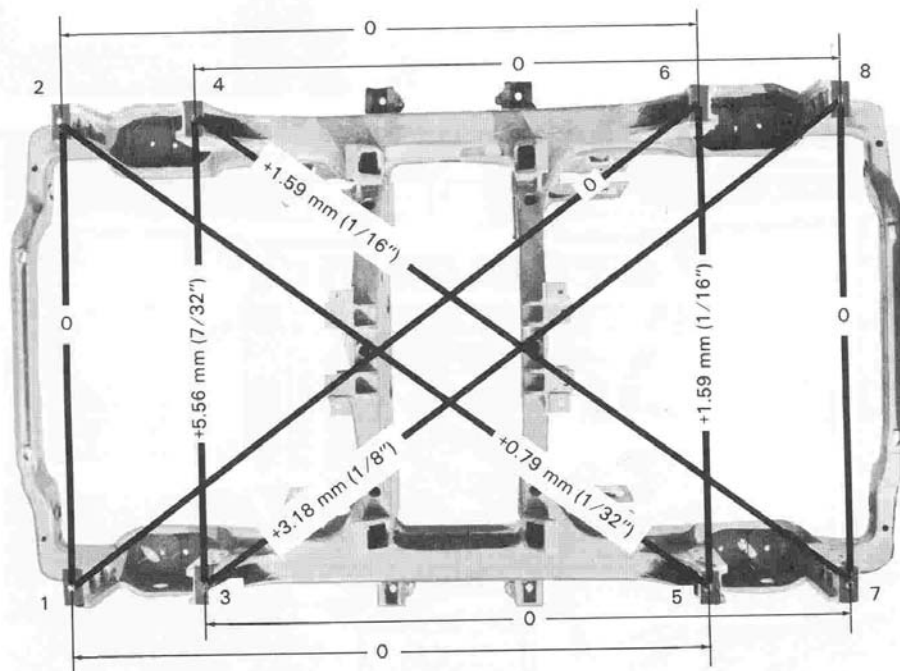

22024

Fig.35 - Typical Example Of Tram Measurements

M.I. 1501

bent inward 3.97 mm (5/32") and No. 4 is bent inward 1.59 mm (1/16"), the diagonals 3-8 and 4-7 will be reduced and diagonal 3-8 will be within the limit of 1.59 mm (1/16"). The same correction would be necessary for pedestals 5-6, if diagonals 1-6 or 2-5, if diagonals 1-6 or 2-5 were out of their limits.

TRUCK SPRINGS

The swing hanger truck assembly is equipped with coil springs at the pedestals or equalizers and elliptic springs between the bolster and spring plank. Various combinations of springs are used to accommodate the loads which may be applied according to the weight specification of a particular locomotive. Spring shim plates and shims of different thickness are used to maintain the proper coupler height. It is important to identify each of the springs according to part number so the spring may be tested at the proper value as listed in the Service Data.

SPRING TESTING

Coil and full elliptic springs may be tested on any reliable calibration type testing press, or a spring testing fixture, Fig. 36, may be made as outlined in File Drawing 647, which is available upon request.

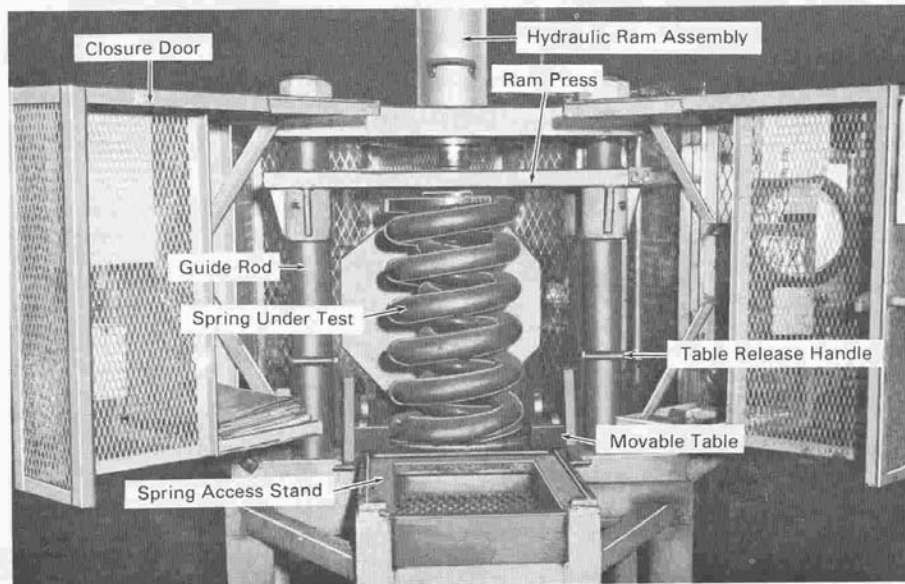
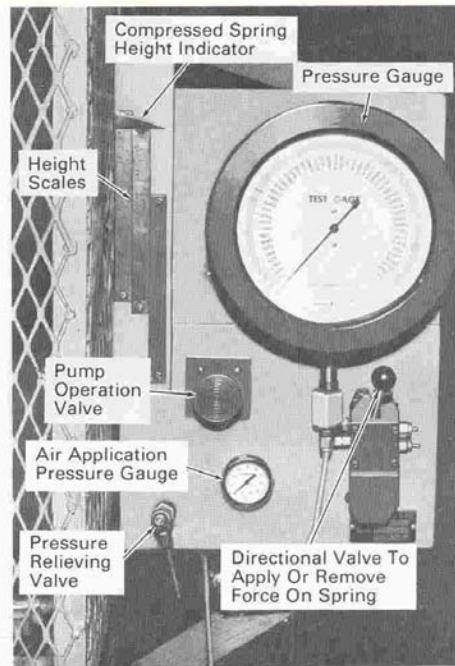

Fig.36 - Spring Testing Fixture

Safety wire mesh encloses the working parts of the fixture. When the two hinged doors at the front of the fixture are opened, a movable table within the fixture can be pulled out to facilitate the application of the spring assembly to be tested. The table with the spring to be tested is then pushed into place in the fixture and the eccentric rollers supporting the table are released to provide complete support for the spring. The protective front access doors are closed and locked in place before testing.

A hydraulic jack arrangement above the spring is actuated to apply force to locate the spring at the correct height for the test. A pressure gauge adjacent to the fixture shows the pounds of force applied to the spring. A pointer at the side of the fixture indicates the height of the spring under test.

To operate the spring tester, the directional valve, Fig. 36, is positioned so the ram will compress the spring when force is applied. The pump application valve is then opened to initiate the force to lower the spring below the static height to be measured. The directional valve is then placed in the neutral or non-directional position. The relieving valve is then opened slightly to adjust the hydraulic ram pressure to the static pressure at which the spring should be tested.

Check the loaded height of the complete spring set and individual springs per information given in the Service Data at the end of this bulletin. Record the spring set height on the initial compression and color code the springs as described below.

COLOR CODING SPRINGS

A color code is used to indicate the loaded height of new coil springs. Brown paint is applied on springs or spring assemblies that are more than 1.59 mm (1/16") but do not exceed 4.76 mm (3/16") limit above the nominal loaded height specified for the spring. Nominal loaded height is the spring height which is used for purposes of identification and as a base for the tolerance limits. Blue paint is applied on springs or spring assemblies that are 1.59 mm (1/16") below to 1.59 mm (1/16") above the nominal loaded height specified for the spring when under the specified test load. Green paint is applied on springs or spring assemblies that are more than 1.59 mm (1/16") but do not exceed the 4.76 mm (3/16") limit below the nominal loaded height specified. All new springs will fall into one of the above three color codes.

White paint should be applied to springs or spring assemblies that are 4.76 mm (3/16") to 7.94 mm (5/16") below the nominal loaded height specified for the spring. This is a service limit and is only for use on used springs. White coded springs should be applied with proper shims, so that their overall loaded height will fall within the limits of brown, blue, or green color coded springs.

Elliptic springs are color coded in a similar manner as shown in the Service Data. Springs which do not fall within the minimum loaded height tolerance can be modified as follows.

Remove both end blocks and install 12.7 mm (1/2") thicker end blocks in their place. After applying the thicker end blocks, recheck the loaded spring height. If the spring height falls within an acceptable height the spring is acceptable for use.

Springs which check above the nominal loaded height must be color coded with an orange paint. Springs which required the thicker end blocks should be banded in sets to retain the end blocks which were used to qualify the spring for use.

Springs that have been tested, color coded, and qualified for use should be stored in a protected area to avoid the formation of rust and pits. Pits can cause stress concentration that may result in spring failure when under load. The springs should be stored in groups corresponding to their color code to make their selection easier.

COIL SPRINGS

Check the spring for any evidence of cracked or broken coils and replace the assembly if found defective. Recommended practice is to replace both spring sets on one spring seat if any coils have failed. However, if a satisfactory loaded height can be maintained on the old spring set, then the old set may be used. Coil springs on the same spring seat should be matched for load height as near as possible.

Replace all double coil spring 8106777 with a current double coil spring. Check the loaded height of the springs at the test load given in Service Data.

FULL ELLIPTIC SPRINGS

Inspect the spring assembly for evidence of cracked, broken or loose leaves or bands. Replace the spring if any of these conditions are found. Elliptic springs on the same truck should be matched as nearly as possible to prevent body lean.

M.I. 1501

Inspect the spring end block for wear at the recess which holds the spring nib. Replace the end block if recess wear exceeds 3.18 mm (1/8").

SEMI-ELLIPTIC SPRINGS

Inspect the spring assembly for cracked or broken leaves and cracked, broken or loose bands. If a broken or cracked leaf is found, the spring assembly should be replaced with a satisfactory assembly.

Replace the pin at the center of the band if it is worn more than 6.35 mm (1/4"). Secure the pin in place with a 3.18 mm (1/8") scarf weld. Replace spring clips if they are broken or worn more than 3.18 mm (1/8") at the 14.29 mm (9/16") radius.

SWING HANGER ASSEMBLY

Swing hangers similar to the one shown in Fig. 37, support the spring planks, bolster springs, and bolster, and the entire weight of the locomotive supported by the truck. The locomotive weight is in turn transferred to the truck frame.



Fig.37 - Swing Hanger Assembly

The swing hangers also function to stabilize the locomotive carbody. When the truck is moved laterally, either by a misaligned track or a curve, the swing hangers will swing like a pendulum, and permit the bolster, bolster springs, and spring plank to move with the carbody. However, as these items move, the lateral force is converted to an upward

curved force by the swing hanger and the force is then absorbed in lifting the locomotive. This same action causes the locomotive to lean when going around a curve. The swing hanger and related items are designed to permit sufficient lateral movement to ensure proper lateral control of the locomotive.

The swing hanger and its associated components such as the swing hanger bearing and bearing block should be inspected and reconditioned, if necessary, prior to reuse.

SWING HANGER

To qualify for reuse the swing hanger should meet requirements for a new part with the following exceptions.

1. The swing hanger pin holes may not be more than 1.27 mm (0.050") out of alignment with each other.
2. The horizontal centerline of the swing hanger pin holes must be parallel with the lower machined swing hanger surface within 0.70 mm (1/32").
3. The dimension from the centerline of the swing hanger to the vertical centerline of each pin hole must be $331.79 \text{ mm} (13-1/16") + 1.59 \text{ mm} (1/16") - 0.79 \text{ mm} (1/32")$.
4. The swing hanger width at the machined faces of the pin hole may not be worn more than 0.79 mm (1/32"). In some instances a groove may be worn in this machined face by the truck frame bushing working out of place. This groove should not exceed 1.59 mm (1/16").
5. If the swing hanger arms are skewed (not parallel to each other) or racked (parallel to each other but not perpendicular to the bottom machined swing hanger surface) beyond dimensional tolerance they must be scrapped.
6. If any indications of cracks are found, the swing hanger must be scrapped. Particular attention should be given to the two bottom corners of the swing hanger and the areas around the pin hole bushings when inspecting for cracks.
7. The area around the pin holes should be carefully inspected for gouges. If there are any gouges extending to or starting at the outer edges of the bore located in the "B" area, Fig. 38, or within the bore in area "A," the swing hanger must be scrapped.

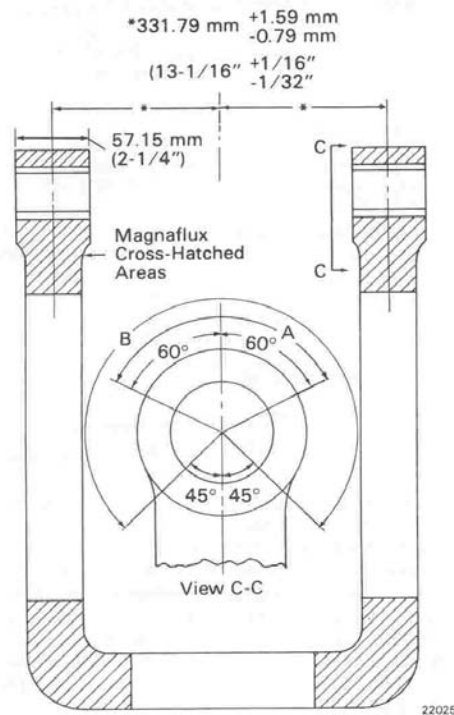

Fig.38 – Swing Hanger Wear Plates

Gouges which are present in areas other than those described above and are not more than 2.38 mm (3/32") deep or 12.7 mm (1/2") long are acceptable. It will be necessary to stress relieve the swing hanger prior to machining if oversized bushings are to be applied.

Stress relieve the swing hanger by heating in suitable furnace at 593° to 649° C (1100° to 1200° F) for a minimum period of 3 hours. Cool the swing hanger slowly in the furnace until the temperature is down to 204° C (400° F) then cool to ambient temperature outside the furnace.

8. If there are any gouges on the outside surface of the pin hole bore that are greater than 0.25 mm (0.010") deep, they should be blended out by grinding. Thickness of the pin hole wall must be at least 23.81 mm (15/16") after grinding or boring for oversized bushings.

When the swing hanger arms are bent in or out from the centerline they may be straightened by cold pressing to conform to the dimensions in Fig. 38. Any swing hanger which has been straightened must be Magnaflux inspected before being used in a truck assembly.

SWING HANGER PIN AND BUSHINGS

The clearance between the swing hanger pin and bushing should be checked before disassembly. The maximum wear on the pin and bushing is determined by the maximum clearance between the two parts as indicated in Fig. 39. The clearance between these parts, when they are new is 0.79 mm (1/32") and the maximum wear limit is 3.18 mm (1/8").

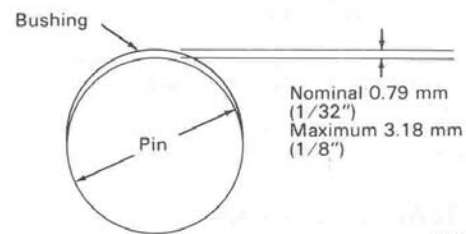

22026

Fig.39 – Swing Hanger Pin And Bushing Wear Limit

If the clearance between the pin and bushing is 3.18 mm (1/8") or more on either side of the swing hanger, all the pins and bushings must be removed and replaced with new parts. This includes both swing hanger bushings as well as both the frame lug bushings. New parts should not be used on one side of the swing hanger and used parts on the other side, nor should new pins or bushings be mated with used pins or bushings.

If inspection was not performed before disassembly, the clearance can be checked by applying the pin to the bushing as in their normal operating position in the truck frame or swing hanger. If the clearance is more than 3.18 mm (1/8") in either case, replace the used parts with new parts.

If it is desirable to qualify the swing hanger components in the disassembled condition, the maximum pin limit is 55.12 mm (2.170"). The maximum limit for bushing 8102087 is 58.37 mm (2.298").

If the swing hanger bushings are to be replaced, the holes in the swing hanger must be 69.80 mm (2.748")

M.I. 1501

+ 0.00 mm (0.000") - 0.03 mm (0.001") to use standard bushing 8102087. If the holes do not meet these requirements, the holes should be enlarged to one of the following diameters to accept one of the oversize bushings.

Diameter of bushing bore	Oversize bushing
70 mm + 0.00 mm - 0.03 mm (2.756" +0.000" -0.001")	8309537
70.56 mm + 0.00 mm - 0.03 mm (2.778" +0.000" -0.001")	8309538
71.07 mm + 0.00 mm - 0.03 mm (2.798" +0.000" -0.001")	8309539

The bushing must have an interference press fit of 0.05 mm (0.002") to 0.10 mm (0.004") to prevent the bushing from working out. Caution should be taken not to exceed the upper limit or a strain may be placed on the swing hanger eye which could cause the eye to fail in service.

BEARING BLOCKS

The clearance between the upper and lower halves of the bearing block should be checked before the truck is disassembled. If this measurement is less than 3.18 mm (1/8"), both halves of the bearing block should be replaced.

When qualifying the bearing blocks after the truck is disassembled, the nominal depth of the upper half at the point of contact with the lower half is 19.05 mm (3/4"). The maximum limit is 21.43 mm (27/32") as indicated in Fig. 40.

The nominal height of the lower half crown is 30.16 mm (1-3/16"). The minimum limit is 27.78 mm (1-3/32").

SPRING PLANK

The spring planks should be cleaned by degreasing in a hot caustic solution. Remove excessive rust and scale to expose the surface to be inspected.

Inspect the spring planks for cracks, bent sections or excessively worn areas. If possible cracks are suspected the spring plank should be Magnaflux inspected. Bent sections may be straightened hot or cold.

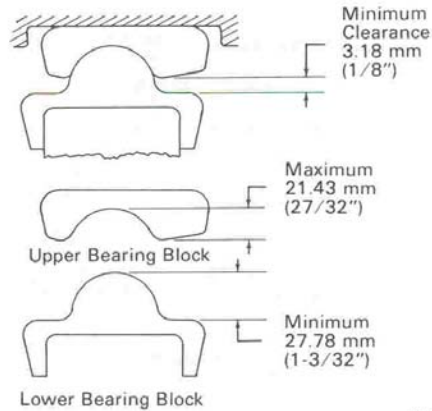

Fig.40 - Swing Hanger Bearing Block Wear Limits

Cracks should be completely removed by grinding, flame cutting or carbon arc gouging before welding repair is made. If the defect is accessible for welding at both sides, a double "V" scarf weld should be made. If only one side of the defect is accessible, a single "V" groove having a root opening large enough to accept a 4.76 mm (3/16") backup plate should be provided. Scarf welds should equal a 60° included angle. During welding procedure the spring plank should be positioned to allow proper handling of the welding electrode and all welding should be in accordance with accepted welding standards.

The clearance between the bottom spring leaf and the spring stop on the four wheel swing hanger spring plank is 3.18 mm (1/8") ± 0.79 mm (1/32") using a 6.35 mm (1/4") spring stop. The condemning limit is 0.79 mm (1/32"). Older model spring planks used a 7.94 mm (5/16") spring stop. When the clearance between these parts reaches 0.79 mm (1/32") the truck should be reconditioned to the 3.18 mm (1/8") ± 0.79 mm (1/32") dimension by the following method.

Grind the top surface of the spring stop until it is 6.35 mm (1/4") from the lowest worn spot on the spring plank. Grind the high spots from between the spring nests to obtain a common plane for all spring seats. Spring planks must not be worn more than 2.38 mm (3/32").

Another method of providing adequate clearance is to remove the 7.94 mm (5/16") spring stop and replace it with a 6.35 mm (1/4") spring stop 8308462.

SPRING PLANK SAFETY STRAPS

Safety straps are used to prevent the spring plank from dropping on the tracks in the event of a swing hanger failure.

Inspect all safety straps for signs of damage which might lead to a strap failure if the spring hanger load should be imposed upon the safety strap. Also check to see that the load would be carried by the safety strap lips and not the holding bolts. If straps are bent they should be cold straightened before they are reused.

There should be at least 9.53 mm (3/8") clearance between the safety strap and the spring plank. If clearance is not sufficient, check for worn swing hanger assembly parts or add a shim between the spring plank and bearing block.

Check the four wheel swing hanger truck to see that there is a clearance between the slack adjuster hinge lock and the safety strap. If a current model slack adjuster is used with an old style safety strap, the safety strap sides will have to be bent inward 4.76 mm (3/16") ± 1.59 mm (1/16") as shown in Fig. 41 to clear the slack adjuster hinge lock.

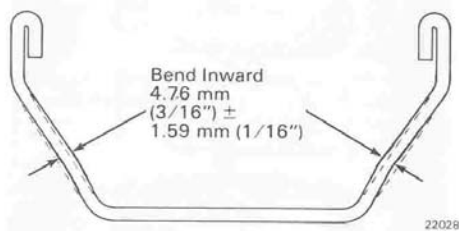

Fig.41 - Safety Strap Modification

EQUALIZER

The equalizer bars on the six wheel swing hanger and switcher trucks used to distribute the locomotive weight evenly to the journal boxes must be checked for small nicks, cracks and excessively worn areas. If any indication of cracking is detected, the equalizer must be scrapped.

Check equalizers for wear at both ends where they contact the journal box wear plates. If they are worn more than 6.35 mm (1/4") at these contact points they must be restored to the original dimension, Fig. 42, by repair welding.

The two inside switcher truck equalizers should be checked for wear along their sides, Fig. 42, from loose brake rigging. If wear exists in this area, the equalizers will be acceptable as long as the wear is not more than 4.76 mm (3/16") deep and the edges of the worn area are ground smooth. When reapplying an equalizer with brake rigging wear, rotate the equalizer end for end in the truck.

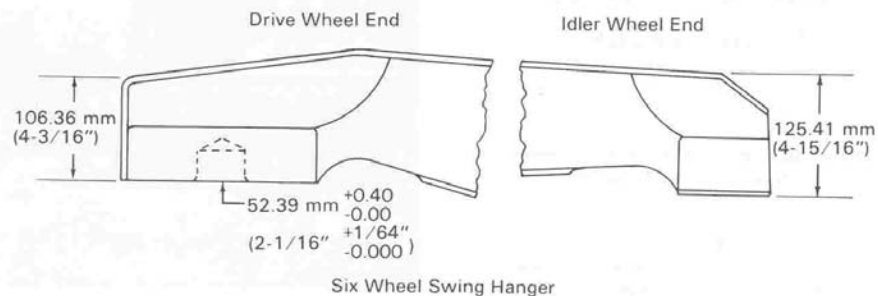
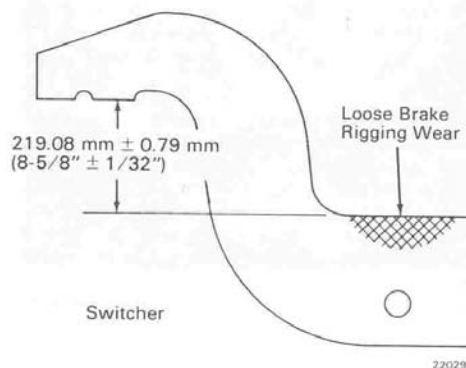

Fig.42 - Equalizer Wear Plates

M.I. 1501

The six wheel swing hanger truck equalizer should be checked to see that the 52.39 mm (2-1/16") hole at the drive wheel end contact surface has not been enlarged beyond 53.98 mm (2-1/8") in any direction or the hole must be welded and rebores to the correct size.

Any equalizer that requires welding must be stress relieved after welding and Magnaflux inspected for cracks. Neither the switcher truck equalizer nor the swing hanger truck equalizer should be bent more than 3.18 mm (1/8") in the overall length. If wear exists on the equalizers at any point other than those described, check the truck to determine the causes of the wear.

BRAKE RIGGING

Inspect the brake rigging to ensure that brake pins, bushings and brake shoes are usable. The wear surfaces of the brake rigging are equipped with replaceable hardened bushings, pins and bolts. Any of these connecting parts that are worn more than 1.59 mm (1/16") should have both parts replaced. Never use a new pin with an old bushing or vice versa.

Cylinder levers, brake levers, brake rods and connecting straps that are bent can be reused if they are restored to their original shape. Connecting straps worn more than 1.59 mm (1/16") should be replaced. If wear is caused by the connecting strap contacting the wheel, the lever pins and bushings associated with the worn strap should be carefully examined. Bolts and nuts that are not subject to wear can be reused if they are not damaged but cotter pins should always be replaced.

ASSEMBLY OF TRUCK SWING HANGER TRUCKS

The swing hanger type truck may be assembled using one of two methods. Procedure A may be used when facilities are available to invert the truck. Procedure B may be used when it is necessary to assemble the truck while the frame is in the upright position.

NOTE

The following assembly procedures can be followed for all swing hanger type trucks. However, since both the six and four wheel trucks are covered some items may not be applicable in all cases.

PROCEDURE A

1. Set the truck frame in an inverted position on the floor with one end sill resting on a turnover fixture similar to that shown in Fig. 43, and the other end blocked so the frame is relatively level. Refer to Service Data for file drawing available to fabricate turnover fixture.
2. Install the inverted bolster into its proper place between the frame transoms. Install coil spring assemblies, spring seats and shims, brake cylinders except on six wheel trucks. Install pedestal liners and equalizer bars to truck frame.

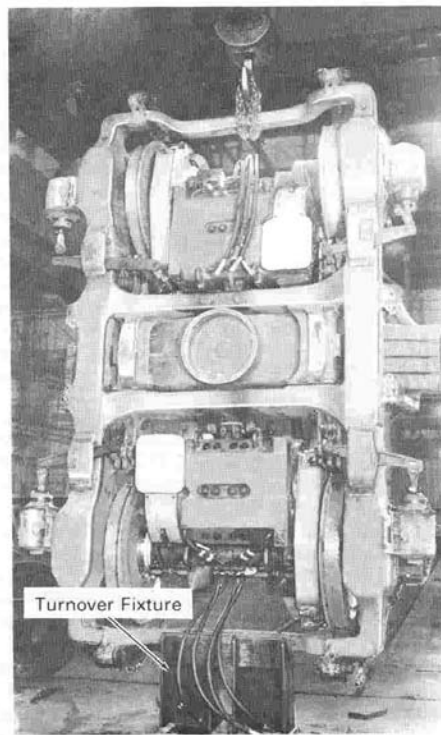

13089

Fig.43 - Turning Over Swing Hanger Truck

3. Install traction motor nose suspension assembly in place between the frame lugs, Fig. 44. Compress the suspension pack assembly by placing temporary blocks between nose pack

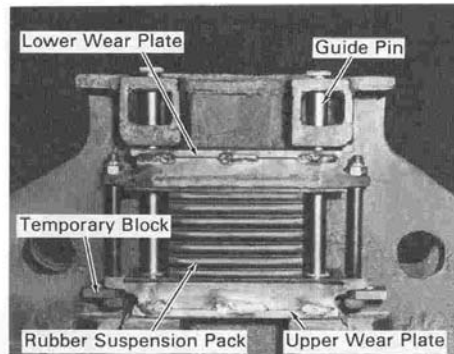

24107

Fig.44 - Installing Nose Suspension Assembly

holder and mounting bolt heads and tightening bolts. Install the suspension pack keeper pins and pin keeper bar.

4. Set the elliptic spring assemblies in place on the bolster and set the spring plank(s) on the elliptic springs.
5. Place upper and lower swing hanger bearing blocks in place on each spring plank and set swing hangers over bearing blocks.
6. Using a locally fabricated elliptic spring compressing fixture, Fig. 45, compress springs until the swing hanger pin holes are aligned with the truck frame boss pin holes. Insert swing hanger pins and remove spring compressing fixture. Install spring plank safety straps and swing hanger pin spacers.

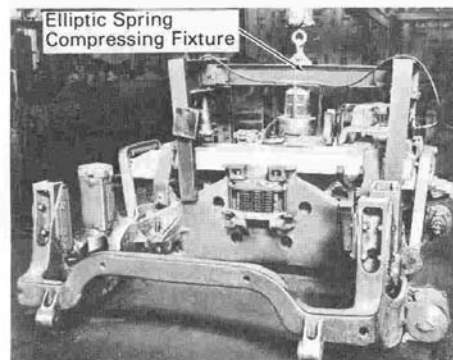

24100

Fig.45 - Compressing Elliptic Springs

Wire swing hangers to safety straps so that swing hangers remain in place when truck is turned over.

7. Install brake lever assemblies and traction motor cooling ducts.
8. Install pre-assembled wheel, axle and motor assemblies in place by lifting the assembly with a lifting fixture similar to the one in Fig. 46, and lowering between the truck frame pedestals until the journal boxes rest on the coil spring seats. Remove temporary blocks from traction motor nose suspension assembly.

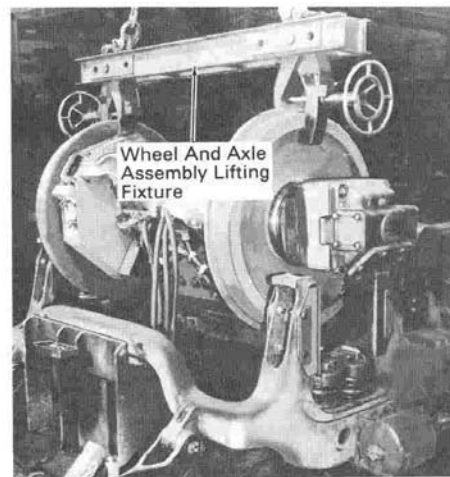

24099

Fig.46 - Installing Wheel, Axle, And Motor Assembly

9. Install clasp brake connection straps and connect them to previously installed brake levers. Install stabilizer bars, sanding guide assemblies and pedestal tie bars and bolt down firmly.
10. Turn the truck assembly over on its wheels by attaching a cable or chain to the end sill opposite the one resting on the turnover fixture and lifting as shown in Fig. 43, until the whole truck assembly rotates end over end 180° and is setting on its wheels. Remove the lifting cable and attach it to the end sill resting on the turnover fixture so that end of the truck can be raised enough to be removed from the fixture.

M.I. 1501

11. Remove wire tying swing hangers to safety straps. Install air brake piping, cylinders, and rigging.
12. Install center bearing wear plate and wear half rings. Apply a coat of grease to the dust guard and install it on the bolster center casting. Apply oil to the truck center bearing as explained under "Lubrication" in this bulletin.

PROCEDURE B

1. Place spring assembly on jacks. Position elliptic springs and bolster assembly on spring plank. Space the wheel and axle assemblies next to the bolster so that when the truck frame is lifted it can be placed over the assemblies.
2. Install coil spring seats, equalizer bars, and pedestal liners.
3. Lift truck frame and lower it over the bolster assembly and the wheel and axle assemblies. Install coil springs, spring seats, shims, and pedestal tie bars.
4. Compress elliptic springs slightly using the jacks under the spring plank. Install upper and lower swing hanger bearing blocks at each spring plank end. While holding the swing hanger in place jack spring plank until swing hanger pin holes are aligned with the truck frame boss pin holes.
5. Insert swing hanger pins. Lower and remove jacks and install spring plank safety straps and swing hanger pin spacers.
6. Apply lifting chains to bails at nose suspension side of traction motor. Connect lifting hoist to chains.
7. Compress traction motor suspension pack assembly by placing temporary blocks between the nose pack holder and mounting bolt heads and tightening bolts, Fig. 47.
8. Hoist motor and place lower lip of support bearing on top of axle, Fig. 48. Rotate motor on axle until traction motor nose suspension assembly can be mounted. Install suspension pack keeper pins and pin keeper bar and remove temporary blocks.

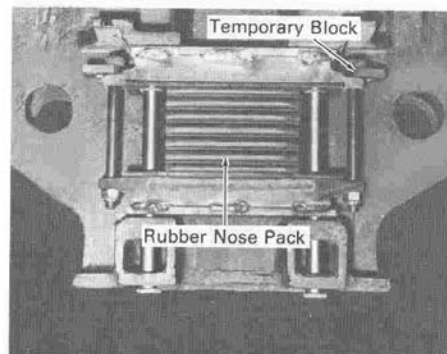

24101

Fig.47 - Compressing Nose Suspension Assembly

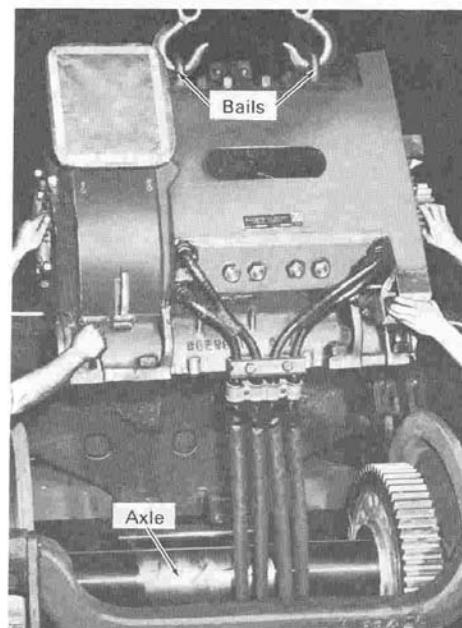

4287

Fig.48 - Installing Traction Motor

9. Install traction motor gear case, outer bearing half, axle guard, support bearing caps and dust guards.
10. Install brake lever assemblies and traction motor cooling ducts.

11. Install clasp brake connection straps and connect them to previously applied brake levers. Install stabilizer bars and sanding guide assemblies.
12. Install air brake piping, cylinders, and rigging.
13. Install center bearing wear plate and wear half rings. Apply a coat of grease to the dust guard and install it on the bolster center casting. Apply oil to the truck center bearing as explained under "Lubrication" in this bulletin.

SWITCHER TRUCKS

1. Set the truck frame on the floor in an upright position with one end sill resting in a turnover fixture similar to the one in Fig. 43.
2. Install the brake cylinders on the brake cylinder mounting pads on each side of the frame.
3. Invert the frame by attaching a cable or chain to the end sill not resting on the turnover fixture and lifting the frame end for end. Be sure to block the frame high enough off the floor so that brake cylinders do not contact the floor.
4. Install the brake levers (with brake shoes), traction motor cooling air ducts, traction motor nose suspension assemblies and coil spring assemblies.
5. The equalizer assemblies, the coil spring seats and elliptic spring hangers should be assembled and then installed in the truck as an assembly. This can be done by setting the inside and outside equalizers in an inverted position on a bench or other convenient stand and bolting the spring hangers in place between the equalizers. Then lay the elliptic springs in place between the equalizers so that spring hangers protrude through the slots in both ends of the elliptic springs far enough to insert the spring hanger key. The equalizers can now be turned over in an upright position and the coil spring seats placed on the top edge of the equalizers. Insert the spring hanger pin through the coil spring seat arms which extend below the elliptic spring. This pin will act as a safety strap to prevent the elliptic spring from dropping to the roadbed in case of a spring hanger failure.

NOTE

There are two types of spring hangers that have been installed in switcher trucks. One is a tee shaped piece with the lower leg protruding through a hole in the end of the elliptic spring. This spring hanger has a slot near the end of the leg where a key is inserted to hold the spring in place. The other spring hanger is an inverted U-shaped piece with its legs bolted to the equalizers and the elliptic spring ends resting in the bottom of the hanger.

6. Set the equalizer assemblies on the frame assemblies so that coil springs fit into the coil spring seats held between the equalizers.
7. Install the pre-assembled wheel, axle and traction motor assembly by lifting the assembly with a lifting fixture similar to the one being used in Fig. 46, and lowering so that journal boxes slide between the truck frame pedestals and rest on the equalizers. The assembly may have to be tilted slightly to allow the traction motor suspension lugs to slip over the traction motor nose suspension assembly. When the wheel and axle assembly is in place, the temporary blocks may be removed from the traction motor nose suspension assembly.
8. Bolt the pedestal tie bars to the pedestals to hold the wheel and axle assemblies in place.
9. Install the clasp brake connection straps and connect them to previously installed brake levers. Install sanding guide assemblies in place between the brake levers.
10. Turn the truck assembly over on its wheels as previously explained, then attach the chain or cable to the end sill resting on the turnover fixture so that end of the truck can be raised enough to be removed from the fixture.
11. Install air brake piping and rigging.
12. Install center bearing wear plate and wear ring. Apply a coat of grease to the dust guard and install it on the bolster center casting. Apply oil to the truck center bearing as explained under "Lubrication" in this bulletin.

SERVICE DATA**SPECIFICATIONS****BOLSTER (ELLIPTIC) SPRINGS****FOUR WHEEL SWING HANGER TRUCKS**

MAXIMUM LOCOMOTIVE WEIGHT	PART NUMBER	COLOR CODE	APPROX. FREE HEIGHT	TEST LOAD	LOADED HEIGHT
Standard Spring 120 658 kg (266,000 lbs)	8106539	-	347.66 mm (13-11/16")	19 278 kg (42,500 lbs)	247.7 mm ± 4.8 mm (9-3/4" ± 3/16")
	8460517	Brown			250.8 mm ± 1.6 mm (9-7/8" ± 1/16")
	8460518	Blue			247.7 mm ± 1.6 mm (9-3/4" ± 1/16")
	8460519	Green			244.5 mm ± 1.6 mm (9-5/8" ± 1/16")
Heavy Duty Spring 127 008 kg (280,000 lbs)	8354463	-	348.46 mm (13-23/32")	23 258 kg (51,275 lbs)	250.8 mm ± 4.8 mm (9-7/8" ± 3/16")
	8460520	Brown			254.0 mm ± 1.6 mm (10" ± 1/16")
	8460521	Blue			250.8 mm ± 1.6 mm (9-7/8" ± 1/16")
	8460522	Green			247.7 mm ± 1.6 mm (9-3/4" ± 1/16")
Extra Heavy Duty Spring 136 080 kg (300,000 lbs)	8413510	-	340.36 mm (13.40")	25 526 kg (56,275 lbs)	250.8 mm ± 4.8 mm (9-7/8" ± 3/16")
	8460524	Brown			254.0 mm ± 1.6 mm (10" ± 1/16")
	8460525	Blue			250.8 mm ± 1.6 mm (9-7/8" ± 1/16")
	8460526	Green			247.7 mm ± 1.6 mm (9-3/4" ± 1/16")
	8322928	-	360.36 mm (14-3/16")	19 278 kg (42,500 lbs)	260.4 mm ± 4.8 mm (10-1/4" ± 3/16")

SIX WHEEL SWING HANGER TRUCKS

PART NUMBER	APPROX. FREE HEIGHT	TEST LOAD	LOADED HEIGHT
8210943	355.6 mm (14")	15 241 kg (33,600 lbs)	276.2 mm ± 4.8 mm (10-7/8" ± 3/16")

SWITCHER TRUCKS

PART NUMBER	APPROX. FREE HEIGHT	TEST LOAD	LOADED HEIGHT
8100102	320.7 mm (12-5/8")	5 221 kg (11,510 lbs)	201.6 mm ± 4.8 mm (7-15/16" ± 3/16")
8100587	327 mm (12-7/8")	6 858 kg (15,120 lbs)	201.6 mm ± 4.8 mm (7-15/16" ± 3/16")

JOURNAL (COIL) SPRINGS
FOUR WHEEL SWING HANGER TRUCKS

MAXIMUM LOCOMOTIVE WEIGHT	PART NUMBER		TEST LOAD	LOADED HEIGHT
	HIGH STRENGTH	REGULAR		
120 658 kg (266,000 lbs)	9085317	8272084	6 414 kg (14,140 lbs)	288.9 mm (11-3/8")
127 000 kg (280,000 lbs)	9094221	8354464	7 190 kg (15,850 lbs)	297.9 mm (11.73")
136 080 (300,000 lbs)	9317671	8413508	7 530 kg (16,600 lbs)	297.9 mm (11.73")

SIX WHEEL SWING HANGER TRUCKS

PART NUMBER	TEST LOAD	LOADED HEIGHT
8100801	7 076 kg (15,600 lbs)	279.4 mm (11")

SWITCHER TRUCKS

PART NUMBER	TEST LOAD	LOADED HEIGHT
8100101	6 688 kg (14,745 lbs)	340.6 mm (13.41")
8100585	9 684 kg (21,350 lbs)	344.5 mm (13-9/16")

REFERENCES

Wheels, Axles, Axle Gears And Pinions	M.I. 1518
New Departure-Hyatt Journal Boxes With Resilient Thrust Units	M.I. 1552
Grease Lubricated Cartridge-Type Journal Bearings	M.I. 1553
Lubricant Specifications	M.I. 1756

EQUIPMENT

File Drawings	
Turnover Fixture (four wheel trucks)	File 250
Turnover Fixture (six wheel trucks)	File 293
Lifting Fixture (traction motor, axle and wheel assembly)	File 288
Tram Marking Tool	File 615
Spring Testing Fixture	File 647
Pedestal Liner Installation Fixture	File 649

NOTE

File drawings can be obtained by contacting Electro-Motive Division Service Department, La Grange, Illinois, 60525.

• • • • **A Service Department Publication** • • • •

Electro-Motive Division Of General Motors La Grange, Illinois 60525